



**ZMX** *plus*

**ZMX+ Series Duplex and  
Triplex Multiplexers  
Operation Instructions**

---

**IMPORTANT**

The first few pages of these instructions contain important information on safety and product conformity. Please read, and ensure that you understand this information before continuing.

---

<b>Important Safeguards</b> .....	4
<b>Safety</b> .....	5
Overview .....	6
Multiplexing .....	7
The Menu System .....	8
Key functions .....	8
Control disk/Arrow keys .....	10
 <b>MODES OF OPERATION</b>	
How to Select PLAY mode .....	11
How to select LIVE mode .....	11
How to select TRIPLEX mode .....	11
How to select VCR view .....	19
 <b>DISPLAY FUNCTIONS</b>	
How to select a camera .....	11
How to select multiscreen displays .....	12
How to select which cameras are shown in a multiscreen display .....	12
How to select active cameo mode .....	13
How to select an active cameo .....	14
How to change the position and colour of display titles .....	16
How to electronically zoom an image .....	17
How to electronically freeze an image .....	18
How to select which images are displayed by which monitors .....	18
How to change the size and position of a Picture In Picture (PIP) Display .....	19
 <b>TELEMETRY FUNCTIONS</b>	
How to select telemetry functions .....	13
How to select a Telemetry Preset .....	15
Recording a Telemetry Preset .....	15
 <b>SEQUENCING</b>	
How to start a camera sequence .....	14
How to create a Full Screen Camera Sequence using the Autolist™ Function .....	14
How to create a Full Screen Playback Sequence using the Autolist™ Function .....	14
 <b>VCR FUNCTIONS</b>	
How to control a VCR with an RS232 interface using your multiplexer .....	18
How to adjust VCR playback contrast and brightness .....	19
VCR Playback .....	19
 <b>ALARM FUNCTIONS</b>	
How to Acknowledge an Alarm .....	16
How to manually activate an alarm .....	16
Alarm Displays .....	20
 <b>MISCELLANEOUS FUNCTIONS</b>	
How to play back a Macro .....	18
How to select the Preset Park facility .....	15
How to select the Random Patrol facility .....	15
How to adjust for Summer time and Winter time .....	17
Motion Indicators .....	21
Video loss .....	21

---

**IMPORTANT SAFEGUARDS**

---

This product is exclusively for use in CCTV applications and has no other purpose.

**Read and Retain these instructions** - All the safety and operating instructions should be read before the unit is operated and should be retained for future reference.

**Cleaning** - Unplug the unit from the supply outlet before cleaning. Use a damp cloth for cleaning. Do not use liquid cleaners or aerosol cleaners.

**Attachments** - Do not use attachments that have not been recommended by the product manufacturer as they may cause hazards.

**Water and Moisture** - Do not use this unit near water. For example, near a bathtub, wash bowl, kitchen sink, or laundry tub, in a wet basement, near a swimming pool, in an unprotected outdoor installation, or any area that is classified as a wet location.

**Accessories** - Do not place this unit on an unstable stand, tripod, bracket, or mount. The unit may fall, causing serious injury to a person and serious damage to the unit. Any mounting of the unit should follow the manufacturer's instructions, and should use a mounting accessory recommended by the manufacturer.

**Ventilation** - Openings in the enclosure are provided for ventilation to ensure reliable operation of the unit and to protect it from overheating, these openings must not be blocked or covered. This unit should not be placed in a built-in installation unless proper ventilation is provided. Do not place directly on other hot equipment, because this may increase its operating temperature.

**Power Sources** - This unit should be operated only from the class 2 isolated power supply provided.

**Plugs** - This unit may be equipped with a 3 wire grounding-type plug, i.e. a plug having a third (grounding) pin. This plug will only fit into a grounding-type power outlet. This is a safety feature. If you are unable to insert the plug into the outlet, contact your electrician. Do not defeat the safety purpose of the plug.

**Power-cord Protection** - Power supply cords should be routed so that they are not likely to be walked on or pinched by items placed upon or against them, paying particular attention to cords at plugs, and the point where they exit from the appliance.

**Overloading** - Do not overload outlets and extension cords as this can result in a risk of fire or electric shock.

**Object and Liquid Entry** - This equipment must be protected from the ingress of foreign materials. Never push objects of any kind into this unit through openings as they may touch dangerous voltage points or short-out parts that could result in a fire or electric shock. Never spill liquid of any kind on the unit.

**Servicing** - There are no user-serviceable parts. Do not remove the covers as this may expose you to dangerous voltages or other hazards. Refer all servicing to qualified service personnel.

**Replacement Parts** - When replacement parts are required, be sure the service technician has used the replacement parts specified by the manufacturer. The use of unauthorised substitute components may result in fire, electric shock or other hazards.

**Safety Check** - Upon completion of any service or repairs to this unit, ask the service technician to perform safety checks to determine that the unit is in proper operating condition.

**Coax Grounding** - If an outside cable system is connected to the unit, be sure the cable system is grounded.

**Lightning** - For added protection of this unit during a lightning storm, or when it is left unattended and unused for long periods, unplug it from the wall outlet and disconnect the cable system. This will prevent damage to the unit due to lightning and power-line surges.

If you have any problems, contact Baxall Security Ltd.

**⚠ WARNING**

- **Installation is only to be carried out by competent, qualified and experienced personnel in accordance with the country of installation's National Wiring Regulations.**
- **Your multiplexer contains no user-serviceable parts inside.**
- **This unit contains a lithium battery whose expected life is in excess of five years. If your multiplexer loses its settings each time it is switched off then the battery needs replacing. In this instance return your multiplexer to Baxall Security Ltd and we will replace the battery.**
- **There is a danger of explosion if the lithium battery is incorrectly replaced. Replace only with the same or an equivalent type recommended by the manufacturer. Dispose of unused batteries according to the manufacturer's instructions.**
- **Do NOT use the 12V power leads in the RS-485 cable UNLESS it is to be used on a one-to-one connection between a unit with 12V power and a unit with no 12V power. For example, from a multiplexer directly to a keyboard that does not have its own power source.**

**In all other circumstances, such as multi-dropped multiplexers, do NOT use the 12V power leads in the RS-485 cable.**

- **Your multiplexer must not be used in a medical and/or intrinsically safe application.**
- **Do not exceed the voltage and temperature limits given in the specification. Only operate your multiplexer in a clean, dry, dust-free environment.**

---

*Note: The multiplexer's main function is to multiplex video and its secondary function is to provide alarms. For this reason, Baxall Security Ltd recommend that you do not use your multiplexer as the main alarm system on your site but install a dedicated intruder/fire alarm where necessary.*

---

This manual covers the following ZMX+ Series Duplex and Triplex multiplexers.

### ZMX+/BD/10, ZMX+/BT/16, ZMX+/CD/16, ZMX+/CT/10

Your multiplexer has a maximum of 10/16 camera inputs. It has 10/16 alarm inputs (which may or may not be associated with each camera), two alarm outputs, two monitor outputs (Monitor A and Monitor B) and VCR output and input connections. A typical installation for a 16 way unit is shown in Figure 1.

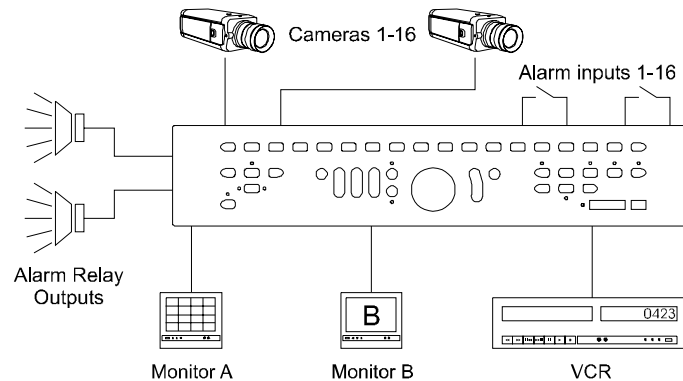

Fig. 1 Typical Installation

The multiplexer provides sophisticated facilities for surveillance monitoring and it can record images from all of the connected cameras to a single video recorder (VCR).

In the typical installation shown above, Monitor A is used for multiscreen, digital images which can be frozen or electronically zoomed. In other words, you can choose to view more than one camera at once on the same screen, you can freeze the images and you can select a camera and electronically enlarge (x2) it. Monitor B provides full screen, live analogue images which cannot be frozen or zoomed. Monitor B is sometimes referred to as a spot monitor in the security industry.

The alarm inputs can be any alarm to any camera. Alarms that have been activated can be indicated on the monitor and an LED located on the front panel of your multiplexer can be made to flash and an audible warning sounded. Depending on the way in which your system has been programmed, you may need to press the alarm button to acknowledge an alarm. Alternatively, an alarm may cancel itself after a fixed period or after the alarm device itself is deactivated. When an alarm does occur, an auxiliary monitor will display the appropriate camera output and, if there are multiple alarms, will sequence between each alarm camera. Monitor A will behave differently depending on which mode the multiplexer is operating in and how it has been programmed. For example, the live camera display on Monitor A can be customised to show the most useful multiscreen possible. Depending on your particular system, some or all of your cameras may have telemetry functions. Where this is the case, you can control them from the multiplexer's keyboard using the telemetry facilities.

**MULTIPLEXING**

The purpose of multiplexing is to reduce the number of VCRs and cassettes required on a site. A multiplexer provides a VCR output with the ability to record all the connected cameras to a single VCR.

**Explanation of Multiplexing**

A PAL compatible TV shows a series of 25 still pictures per second which give the impression of motion. Normally a VCR would record every picture. Time division multiplexing, as performed by your multiplexer, means that all the camera signals are combined, one picture from each camera in turn and then back to the first (see Figure 2). This means that a small amount of information is lost e.g. for a 10 camera installation, 1 out of every 10 images is recorded giving rise to a slightly jerky image on playback.

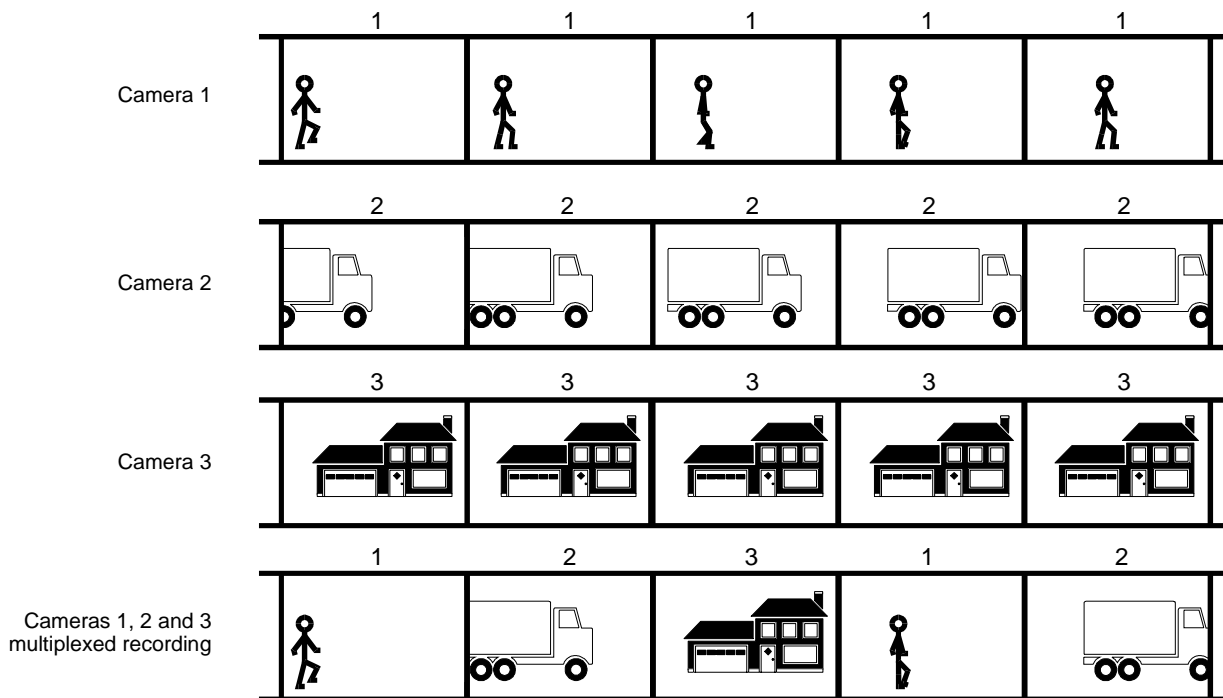

Fig. 2 Multiplexing

**Time Lapse VCRs**

The time-lapse VCR reduces the number of cassettes required for a site. It also reduces the amount of time spent changing cassettes and the amount of storage space required for them. Time-lapse VCRs record and play tapes more slowly by recording fewer images. The speed of operation for a normal VHS VCR is 3 hours. The table below gives examples of how many fields can be recorded on a three hour tape per camera in various time-lapse modes.

Time Lapse mode	Fields per second with 1 camera	Fields per second with 8 cameras	Fields per second with 16 cameras
3 hour	50	6.25	3.125
12 hour	12.5	1.56	0.78
24 hour	6.25	0.78	0.39
48 hour	3.13	0.39	0.2

Table 1 Time-Lapse Modes and Recorded Fields per Second

THE MENU SYSTEM

More advanced operation of your multiplexer involves use of the menu system. Your multiplexer provides user-friendly, on-screen menus for entry of user data such as titles and for the selection of options (see the Programming Reference manual for details).

Note that the alarm key is disabled while the menu system is active.

KEY FUNCTIONS

A brief description of the various keys on your multiplexer is given below. Figure 3 shows the location of each key and indicator LED.

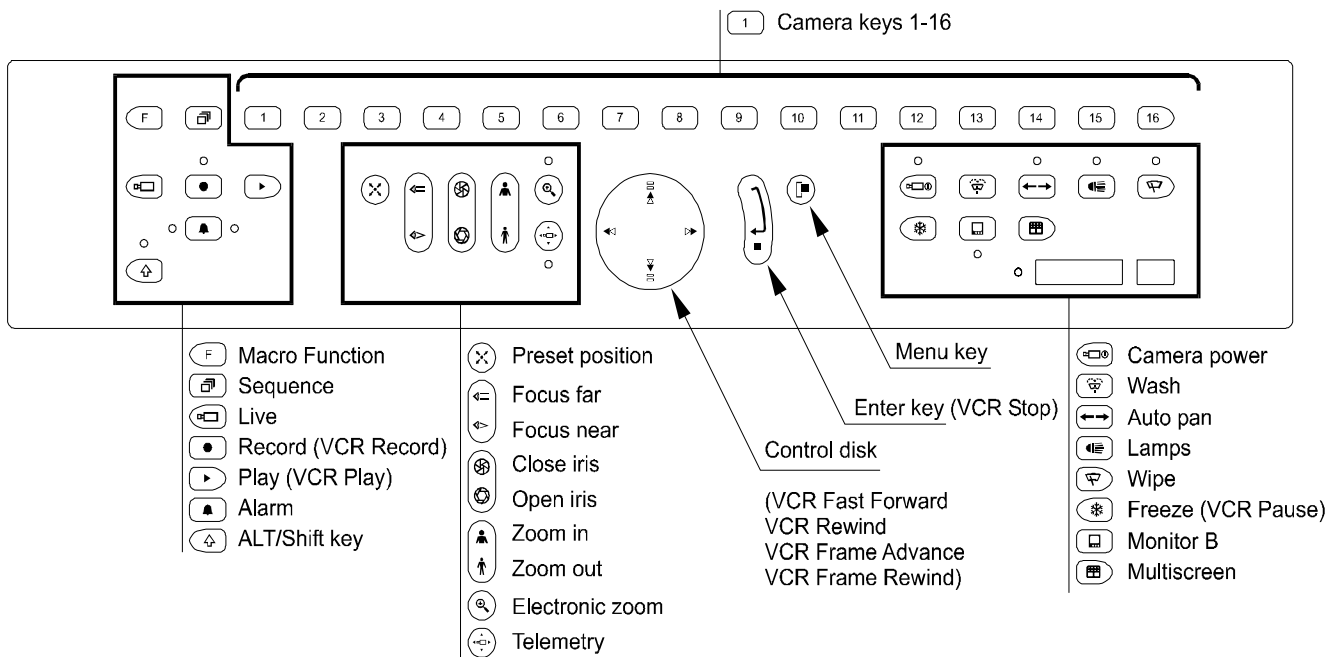

Fig. 3 Key Locations

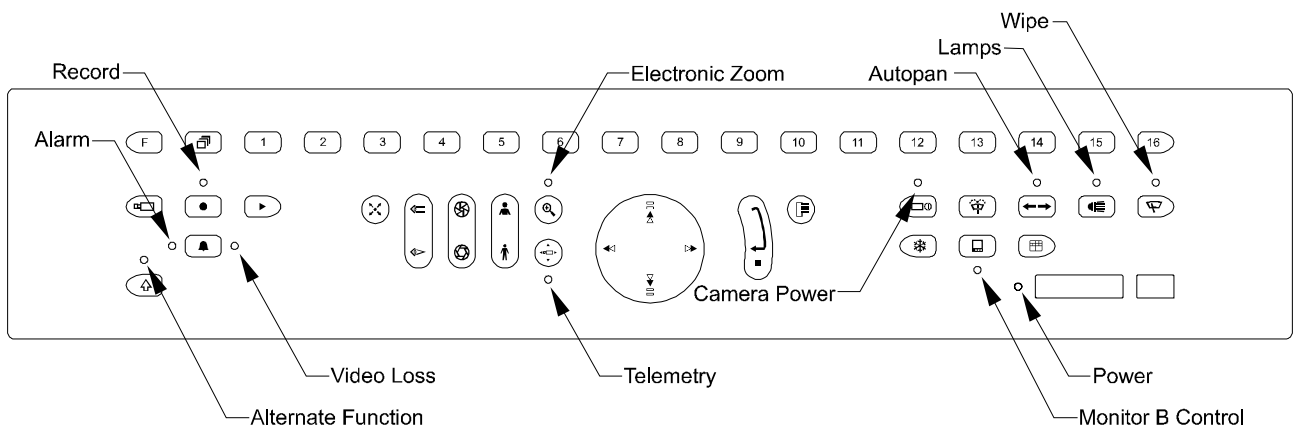





























Fig. 3a LED Locations

KEY FUNCTIONS

KEY	DESCRIPTION
	<b>CAMERA KEY</b> Used to select cameras, macros etc.
	<b>MACRO FUNCTION</b> Used in conjunction with a camera key to select one of 16 macros
	<b>SEQUENCE</b> Starts or stops full or multiscreen sequences.
	<b>LIVE</b> Permits the viewing of live digital camera images.
	<b>RECORD</b> This key is permanently selected and your multiplexer is always in record mode. The indicator above the key is always illuminated. (Also used with ALT key as VCR Record)
	<b>PLAY</b> Selects Play and TRIPLEX modes. (Also used with ALT key as VCR Play)
	<b>ALARM</b> Depending on how your system has been set up, you may need to press the alarm key to clear the alarm.
	<b>ALT</b> Provides access to alternate functions on certain keys. When pressed, the multiplexer enters the ALT mode. ALT mode stays active until the ALT key is pressed again.
	<b>PRESET</b> Use this key in conjunction with Camera keys 1 - 8 to select a preset camera position
	<b>FOCUS FAR</b> Allows you to adjust the focus of a camera for distant scenes. The camera must first be selected and the telemetry enabled.
	<b>FOCUS NEAR</b> Allows you to adjust the focus of a camera for close scenes. The camera must first be selected and the telemetry enabled.
	<b>CLOSE IRIS</b> Allows you to close the camera iris. The camera must first be selected and the telemetry enabled.
	<b>OPEN IRIS</b> Allows you to open the camera iris. The camera must first be selected and the telemetry enabled.
	<b>ZOOM IN</b> Causes the camera lens to zoom-in. The camera must first be selected and the telemetry enabled.
	<b>ZOOM OUT</b> Causes the camera lens to zoom-out. The camera must first be selected and the telemetry enabled.
	<b>ELECTRONIC ZOOM</b> This operates a x2 electronic zoom on the full screen digital image.
	<b>TELEMETRY</b> Enables or disables telemetry functions.
	<b>ENTER</b> Allows you to make menu selections. (Also used with ALT key as VCR Stop)
	<b>MENU</b> Allows you to enter the menu system. Press the menu key once then enter your password. To exit from the menu system, press the menu key to close each level of menu until the menu system is exited.
	<b>CAMERA POWER</b> Enables you to turn the power on or off for the selected camera. The camera must first be selected and the telemetry enabled. A red indicator will be lit when the camera power is on.
	<b>WASH</b> Press to activate camera screen wash. The camera must first be selected and the telemetry enabled.
	<b>AUTOPAN</b> Allows you to start or stop camera auto panning. The camera must first be selected and the telemetry enabled. A red indicator will be lit when autopan is enabled.
	<b>LAMPS</b> Allows you to switch the selected camera's lamps on or off. The camera must first be selected and the telemetry enabled. A red indicator will be lit when the lamps are on.
	<b>WIPE</b> Allows you to switch the selected camera's wipe function on or off. The camera must first be selected and the telemetry enabled. A red indicator will be lit when the wipe function is on.

## KEY FUNCTIONS

KEY	DESCRIPTION
	<b>FREEZE</b> This key will freeze the current image. Press the Freeze key again to unfreeze the image. Note that in a full screen display, you must turn off Freeze before you can select another camera. (Also used with ALT key as VCR Pause)
	<b>MONITOR B</b> Toggles between Monitors A and B.
	<b>MULTISCREEN</b> Allows you to step through the various permissible multiscreen layouts. Layouts are selected sequentially e.g. 16 way, 13 way, 10 way, 9 way, 7 way, Quad, PIP, 16 way, 13 way, etc. Note that multiscreen selection is valid in LIVE, PLAY and TRIPLEX modes. See page 12 for more information

## CONTROL DISK/ARROW KEYS

The control disk /Arrow key combination is used to perform various functions. It is used to move around the electronic zoom area or navigate in the menu system, to pan and tilt the selected camera when in telemetry mode, to move and size the small cameo in the PIP multiscreen display format, to control a VCR, and to change the brightness and contrast in playback mode.

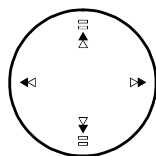

Control disk / Arrow keys

**Moving around an electronically zoomed area**

Use the left/right and up/down arrow keys on the control disk to scroll the electronically zoomed image around the monitor.

**Navigating the menu system**

The left/right and up/down arrow keys along with the enter key are used to move through the menus when in menu mode. See the programming manual for more information.

**Panning and tilting cameras**

The left/right and up/down arrow keys control camera pan left/camera pan right and camera tilt up/camera tilt down. They are used in conjunction with the telemetry key to gain control of the selected camera.

**Move and re-size Picture In Picture (PIP)**

When you are displaying the PIP multiscreen format, pressing the up and down arrow keys switches the small cameo to top/left or bottom/right respectively. The left and right arrow keys toggle the cameo between three preset sizes: left key to step down in size, right key to step up in size.

**To move the active cameo selection about a multiscreen display format**

When you are displaying a multiscreen format, pressing the enter key causes the active cameo to be activated (this is indicated by flashing cameo/camera title text). You can select a different cameo using the arrow keys.



**Controlling VCR functions**

When used in conjunction with the ALT key, the control disk provides control of the VCR functions Fast Forward, Rewind, Frame Advance and Frame Rewind.

---

**MODES OF OPERATION**

---

Your multiplexer has several modes of operation, LIVE, RECORD, PLAY and TRIPLEX. The RECORD mode is always selected whilst PLAY, LIVE and TRIPLEX modes are selected using the LIVE  and PLAY  keys.

**LIVE mode** 

This mode displays digital live camera images on Monitor A. Several multiscreen display formats can be selected - see figure 4.

**RECORD mode** 

Record mode provides a multiplexed output to the VCR. Single images from up to 10/16 video inputs are assembled to form a continuous video signal which is then recorded onto the VCR - see figure 2.

**PLAY mode** 

This mode enables a previously recorded multiplexed tape to be played back.

**TRIPLEX Mode (ZMX+/BT/16 and ZMX+/CT/10)**

TRIPLEX mode allows the user to view both live and playback video at the same time on Monitor A while the unit continues to record multiplexed signals (two VCRs are required for this). There are several different multiscreen display formats that can be selected in TRIPLEX mode - see figure 4.

---

**HOW TO SELECT A CAMERA**

---



Select a camera by pressing the corresponding camera key (1 to 10 or 1 to 16). This will display the selected camera full-screen.

Selecting a camera will stop a sequence that is running or change a multiscreen display back to a full screen display.

---

**HOW TO SELECT PLAY MODE**

---

This mode enables a previously recorded multiplexed tape to be played back. Your VCR must be playing in order for you to view prerecorded data. Start your VCR manually or if using a VCR connected via RS232, by using the VCR Play macro (ALT  and Play ). When PLAY mode is entered by pressing the Play key, the multiplexer will automatically revert to the multiscreen format that was last selected for playback. Playback may be viewed in full screen or multiscreen formats - see figure 4. Your multiplexer automatically reconstructs, for each camera, its identification number, its status, and the date and time which was current at the time of recording.

Your multiplexer can decode several VCR formats. The default format decodes recordings from Baxall ZMX+ multiplexers. Other modes can decode ZMX, DM compatible recordings and Sensomatic ROBOT recordings. When Play mode is entered, an on-screen flag is displayed for about three seconds showing the playback format selected.

---

**HOW TO SELECT LIVE MODE**

---

This mode displays digital live camera images on Monitor A. Several multiscreen display formats can be selected using the multiscreen key - see figure 4. LIVE mode is selected by pressing the LIVE key .

---

**HOW TO SELECT TRIPLEX MODE (ZMX+/BT/16 AND ZMX+/CT/10)**

---

TRIPLEX mode allows you to view both live and playback video at the same time on Monitor A while the unit continues to record multiplexed signals (note that two VCRs are required for this). There are several different multiscreen display formats that can be selected in TRIPLEX mode using the multiscreen key - see figure 4.

To select TRIPLEX mode, you must have Monitor A selected. Press the PLAY key to set the multiplexer into PLAY mode and then press the PLAY key again to select TRIPLEX mode. The Monitor A multiscreen display will be divided into PLAY and LIVE areas as shown in figure 4. These can be selected using the multiscreen

**HOW TO SELECT TRIPLEX MODE (ZMX+/BT/16 AND ZMX+/CT/10)**

key. To exit TRIPLEX mode, press the PLAY key to return to normal PLAY mode, or the LIVE key if you wish to return to LIVE mode.

*Note: You cannot select TRIPLEX mode from a full-screen, PLAY mode Monitor A display. The display needs to be divided into more than one cameo in order that live and playback images may be viewed.*

The TRIPLEX multiscreen format can be changed using the multiscreen key. The order in which the TRIPLEX multiscreens appear is shown in figure 4. There is a subtle change of colour in the borders between the cameos from pale grey to white as you change from PLAY mode to TRIPLEX mode.

**HOW TO SELECT MULTISCREEN DISPLAYS**

Your multiplexer allows up to 10 or 16 simultaneous camera images to be displayed on Monitor A. Depending on the viewing mode selected, these can be live images, images played back from a VCR or a combination of both. The multiscreen key  will select the available formats cyclically e.g. 16 way, 13 way, 10 way, 9 way, 7 way, quad, PIP, back to 16 way, 13 way, etc. The individual areas of a multiscreen are called cameos.

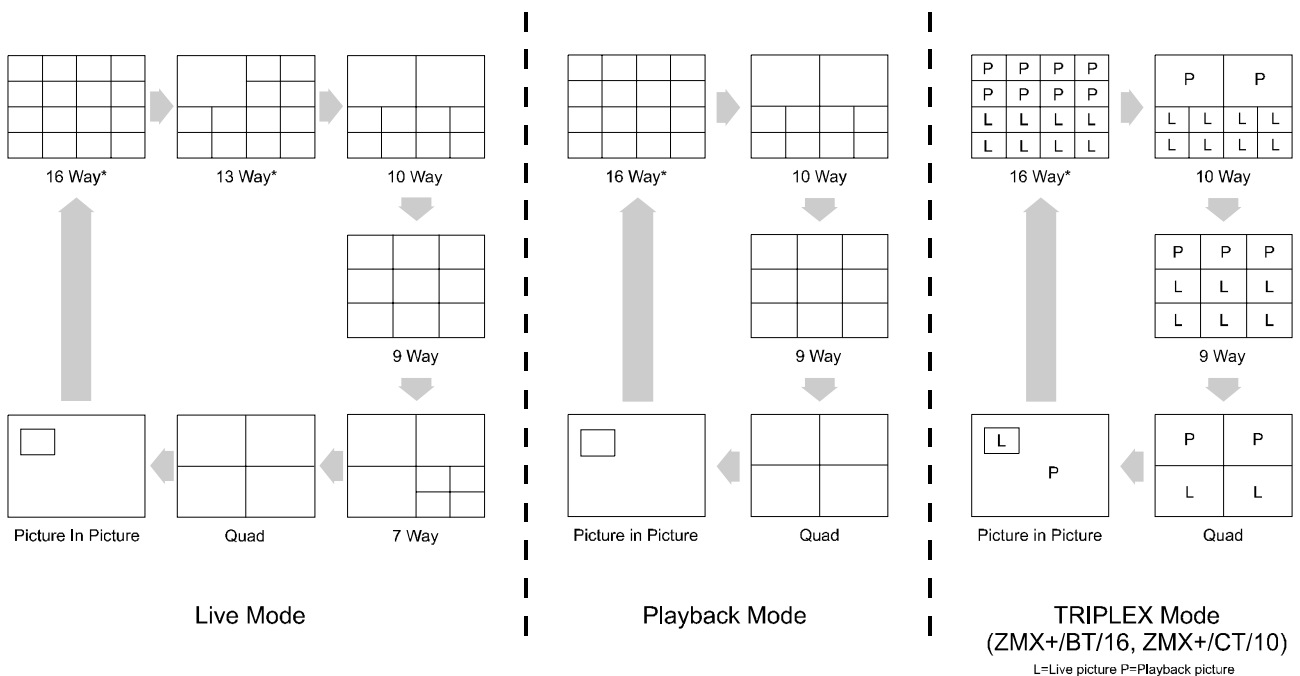

Fig. 4 Multiscreen Formats

\*16 and 13 way displays are available only on 16 way models.

**HOW TO SELECT WHICH CAMERAS ARE SHOWN IN A MULTISCREEN DISPLAY**

When a multiscreen display is being viewed, it is possible to select which camera is displayed in each cameo of the display. This is done by selecting a cameo and then selecting which camera is assigned to the cameo.

1. Select active cameo mode by pressing the enter key whilst in a multiscreen display.
2. Using the arrow keys, move to the cameo you wish to change. This is indicated by the camera title flashing within the selected cameo.
3. Press the desired camera key.

If you have set up the camera numbers and locations which are to be displayed in a particular multiscreen, then the unit will automatically save that selection and will display the same camera selection and locations each time that particular multiscreen is selected. (This is saved in volatile memory.)

For example, if cameras 9, 4, 7 and 2 are selected for the quad multiscreen, then whenever you select the

---

**HOW TO SELECT WHICH CAMERAS ARE SHOWN IN A MULTISCREEN DISPLAY**

---

quad multiscreen, those cameras will be displayed, and in the same positions as you originally selected.

If you switch from a multiscreen display to a full-screen camera image, then when the Multiscreen key is next pressed, you will automatically return to the last multiscreen format that was being viewed.

For example, if you are viewing a 7 way multiscreen and switch the display to a full-screen display, then if the Multiscreen key is pressed later, the Monitor A display will switch directly back to the 7 way screen format.



---

**HOW TO SELECT TELEMETRY FUNCTIONS**



---

Many cameras are equipped with remotely controllable pan and tilt heads, wash/wipe facilities, lens focus and zoom etc. Where fitted, these features are controlled as follows:



**Full screen display**

1. Select the camera by pressing the camera key
2. Enable telemetry by pressing the Telemetry key 
3. Press the telemetry function required (e.g. to perform a camera screen wash, press the Wash key ).

**Multiscreen display**

1. Select active cameo mode by pressing the enter key
2. Using the arrow keys, move to the cameo of the camera you wish to control
3. Enable telemetry by pressing the Telemetry key 
4. Press the telemetry function required

**Selecting a telemetry function on Monitor B**

1. Select Monitor B by pressing the Monitor B key 
2. Select the camera to be controlled by pressing the camera key
2. Enable telemetry by pressing the Telemetry key 
3. Press the telemetry function required (e.g. to perform a camera screen wash, press the Wash key ).

---

**HOW TO SELECT ACTIVE CAMEO MODE**

---

A multiscreen display is made up of two or more areas called *Cameos*. Any camera can be displayed in any position within a multiscreen display. The default multiscreen displays, show the cameras in ascending order. In LIVE mode, you can display one camera in more than one position, while in PLAY mode each camera can be displayed once only on each multiscreen.

To make it simple for you to select a camera for display in a cameo, the multiplexer uses the concept of *Active Cameos*. An active cameo is simply an on-screen indication of which particular cameo will be affected by the next front panel keystroke. Active cameos are used mainly to give you a simple way of specifying which camera is to be displayed in which cameo, but other useful functions such as cameo freeze and zoom to full screen are also available. To assign a camera to an active cameo, simply press the appropriate camera key. The selected camera is added to the cameo and the next cameo in the multiscreen becomes the active one.

To select active cameo mode, press the Enter key  while displaying any multiscreen. The top left cameo will be the initial active cameo. The active cameo is indicated by flashing the camera number and the camera title. An active cameo will only be present if you specifically select active cameo mode. Use the arrow keys to select a different cameo.

The active cameo mode will stay active for 15 seconds after the last key is pressed, or until the Enter key is pressed again to exit the mode. Active cameo mode will also stop immediately if a new multiscreen display is selected, or if you switch between LIVE, PLAY and TRIPLEX modes.

---

**HOW TO SELECT AN ACTIVE CAMEO**

---

You may want to select a particular cameo in a multiscreen display in order to zoom in on it or freeze the image etc. To select a cameo you must first be in active cameo mode. This is achieved by pressing the enter key whilst in a multiscreen display. The cameo's title will flash to show which cameo is currently selected. Use the arrow keys on the control disk to select a different cameo. The selected cameo will be indicated by its flashing title. Note that if the ALT key is pressed and the multiplexer is in ALT mode, then pressing the enter key will emulate the VCR stop function. Ensure that the multiplexer is not in ALT mode (the LED above the ALT key will be lit if ALT mode is active).

---

**HOW TO CREATE A FULL SCREEN CAMERA SEQUENCE USING THE AUTOLIST™ FUNCTION**

---

Your multiplexer is equipped with a system which allows you to 'teach' it which cameras are to be sequenced and for how long. This facility is called Autolist™. Autolist will record your actions as you select cameras including the length of the pauses between selections. Up to 32 camera entries may be made in each Autolist and each monitor can have an independent Autolist sequence programmed for it. To start the Autolist function enter full screen Live mode for the desired monitor. Next, press and hold the Alarm (▲) key then press the Sequence (◻) key until the text **PGM** (program mode) is displayed. Next, press the camera key of the first camera you require in the sequence. After the required dwell time for this camera, press the camera key corresponding to the next camera in the sequence. Continue in this way until the desired sequence has been built up. Next, press the Sequence key again to stop the recording. You can stop the recording of a sequence at any time by pressing any key other than a camera key. Dwell times may be up to 30 seconds long.

Note that if the full screen dwell time is subsequently altered from within the menu system, the sequence will revert to one of all cameras in numerical order for the newly selected dwell time

---

**HOW TO START A CAMERA SEQUENCE**

---

Pressing the sequence key (◻) will display selected cameras in a preselected order and for a preselected time. The cameras and dwell times are selected using the Autolist function or by using the menu system - see the Programming Reference manual for further information.

In multiscreen live, playback or TRIPLEX modes, it is possible to view all the cameras that are not currently selected for display by pressing the sequence key. These cameras will be shown, in sequence, within the lower right hand cameo in the live picture area of the display. For example, if a Quad display is being viewed in TRIPLEX mode then the top two images will be playback images and the bottom two images will be live. If the live images are from camera 1 (bottom left) and camera 2 (bottom right) cameras 3 to 10/16 will not be shown. Pressing the sequence key will change the display to show camera 1 (bottom left) as before but the bottom right cameo will now cycle through the remaining cameras 2 through 10/16. The image from each camera will be shown for period determined by the multiscreen dwell time setting accessed through the menu system. The camera sequence is not programmable.

---

**HOW TO CREATE A FULL SCREEN PLAYBACK SEQUENCE USING THE AUTOLIST™ FUNCTION**

---

Your multiplexer is equipped with a system which allows you to 'teach' it which cameras are to be played back in which sequence and for how long. This facility is called Autolist™. Autolist will record your actions as you select cameras including the length of the pauses between selections. Up to 32 camera entries may be made. To start the Autolist function enter full screen Playback mode. Next, press and hold the Alarm (▲) key and then press the Sequence (◻) key until the text **PGM** (program mode) is displayed. Next, press the camera key of the first camera you require in the sequence. After the required dwell time for this camera, press the camera key corresponding to the next camera in the sequence. Continue in this way until the desired sequence has been built up. Next, press the Sequence key again to stop the recording. You can stop the recording of a sequence at any time by pressing any key other than a camera key. Autolist playback is only available on monitor A.

**△ CAUTION**



This option must be used with caution if the VCR is set to time lapse speeds while playing back. When sequencing the display during playback, **do not** set the VCR's play speed such that the frequency at which any one camera is played back off the tape is slower than the frequency that the sequence list will switch through cameras in the list. It is recommended that the VCR is set to its normal speed (3 hours for PAL) when sequencing playback displays.

---

**HOW TO SELECT A TELEMETRY PRESET**

---

Your multiplexer can store up to eight preset camera positions for each camera. They can be recalled at any time as follows:



1. Select the camera by pressing its corresponding camera key
2. Enable telemetry for the camera by pressing the Telemetry key 
3. Press the Preset key 
4. Press the number of the preset (1 to 8) using the camera keys

---

**RECORDING A TELEMETRY PRESET**

---

Your multiplexer can store up to eight preset camera positions for each camera. The camera is first positioned then the position is stored as follows:

1. Select the camera by pressing its corresponding camera key
2. Enable telemetry for the camera by pressing the Telemetry key 
3. Steer the camera to the desired location using the arrow keys
4. Press the function key 
3. Press the Preset key 
4. Press a number key (1 to 8) to store the preset



---

**HOW TO SELECT THE PRESET PARK FACILITY**

---

Preset Park is an automatic command to a controllable camera to move it to preset position 1 if it has not received any telemetry signals for approximately 10-20 minutes. Whether Preset Park is enabled or disabled for a particular camera can be verified by selecting the camera and pressing the Telemetry key. If Preset Park is enabled, the telemetry indicator will be displayed as **TL1** (full screen) or **1** (cameo). If the Preset Park facility is disabled, the telemetry indicator will be displayed as **TEL** (full screen) or **T** (cameo). In order for the Preset Park facility to operate, preset position 1 must be programmed for the camera.

To disable or enable Preset Park for a camera:

1. Select the camera by pressing its camera key.
2. Press the Telemetry key 
3. Press the Preset key 
4. Press the enter key 

---

**Notes**

- 1) *The key combination above has a toggle action and can be used to disable/enable Preset Park.*
  - 2) *Preset Park is automatically disabled if Random Patrol is enabled for the camera.*
- 

---

**HOW TO SELECT THE RANDOM PATROL FACILITY**

---

Random patrol is an automatic command to a controllable camera to move to a preset position, randomly selected from preset positions 1 to 8, made at random intervals between 1 and 4 minutes. For the facility to work fully, all the preset positions must have been programmed for the camera (see the Programming Reference manual).



The default state for all your cameras is for Random Patrol to be disabled. Whether Random Patrol is enabled or disabled for a particular camera can be verified by selecting the camera and pressing the Telemetry key. If Random Patrol is enabled, the telemetry indicator will be displayed as **TL2** (full screen) or **2** (cameo). If the Random Patrol facility is disabled, the telemetry indicator will be displayed as **TEL** (full screen) or **T** (cameo).

---

**HOW TO SELECT THE RANDOM PATROL FACILITY**

---

To enable Random Patrol for a camera:

- 1) select the camera
- 2) press the Telemetry key 
- 3) press the Preset key  and the Sequence key .

---

**Notes**

- 1) *The key combination, Preset and Sequence has a toggle action and can be used to disable Random Patrol on a camera for which it has been enabled.*
  - 2) *Another way of disabling Random Patrol on a camera is to select it, activate telemetry and to use any telemetry key.*
  - 3) *Random Patrol is disabled automatically if Preset Park is enabled for the camera.*
  - 4) *While telemetry mode is active (the LED under the TELEMETRY key is illuminated) for a particular camera, Random Patrol is suspended on all the other cameras. If Random Patrol is enabled on the selected camera, however, it will be active on that camera, even when in telemetry mode. As soon as telemetry is deactivated (by pressing the TELEMETRY key), Random Patrol becomes active for all the cameras for which it has been enabled.*
- 

---

**HOW TO ACKNOWLEDGE AN ALARM**



---

Certain alarm conditions that arise, require operator intervention (i.e. a latched alarm). Usually, the monitor displays are configured to provide a customised view for each alarm and so you will need to acknowledge the alarm in order to return to your previous settings. An alarm is acknowledged simply by pressing the alarm cancel/acknowledge key .

---

**HOW TO MANUALLY ACTIVATE AN ALARM**

---

Alarms are normally associated with cameras. For example, a motion sensor covering a room might be configured, when activated, to call up a camera which provides the operator with a view of the room and another camera covering the entrance to the room. However, you can initiate or force any of the alarms associated with a camera by pressing and holding the alarm cancel/acknowledge key  followed by the desired camera key.

---

**HOW TO CHANGE THE POSITION AND COLOUR OF DISPLAY TITLES**

---

Camera titles can be displayed either at the top or at the bottom of the camera view, or the titles can be switched off. The titles can also be displayed as black, grey, or white characters. This feature is selectable for each camera during either LIVE, PLAY modes.

To change the title positions and colours, select any camera in full-screen LIVE mode by pressing a camera key. Press the ENTER key to select the title position and colour according to the table below. Repeated key presses will cycle through the list.

Title Position	Title Colour
Top	Black
Top	White
Top	Grey
Bottom	Black
Bottom	White
Bottom	Grey
No title (numbers still displayed)	-

---

**HOW TO CHANGE THE POSITION AND COLOUR OF DISPLAY TITLES**

---

**Notes**

- 1) *Settings only affect Monitor A. Monitor B IS not affected.*
- 2) *In any full-screen Monitor A display, the title text and colour will move from the top to the bottom of the screen, and change colours according to the above scheme. If you want to change the colour of the date and time text, you can only do this if camera 1 is displayed full-screen. In this case, each time the above cycle is completed, the date and time display colour will change from white to grey to black and back to white again.*

---

**HOW TO ADJUST FOR SUMMER TIME AND WINTER TIME**

---

Many countries adjust the time twice a year by one hour. A special function is installed on your Multiplexer to allow adjustment without having to enter the menu system.

In March/April the time can be advanced by one hour (once only) by pressing the FUNCTION key (F) followed by the SEQUENCE key (S). The same key sequence when used in September/October will decrement the time by one hour (once only).

**△CAUTION**

Take care not to operate Summer/Winter adjustment accidentally because it cannot be undone without entering the menu system.

---

**HOW TO ELECTRONICALLY ZOOM AN IMAGE**

---

You can electronically enlarge (zoom) any camera image by a factor of two. The word **ZOOM** is displayed on screen while the image is zoomed.

**Electronic zoom in a full screen display:**

1. Press the zoom key (Z) once to activate the zoom facility.
2. Use the arrow keys to scroll the zoomed image around the monitor.
3. Press the zoom key to deactivate electronic zoom.

**Electronic zoom in a multiscreen display**

1. Enter active cameo mode by pressing the enter key.
2. Use the arrow keys to move to the desired cameo.
3. Press the zoom key (Z) once to change the screen to a full screen display of the selected cameo
4. Press the zoom key again to activate the zoom facility.
5. Use the arrow keys to scroll the zoomed image around the monitor.
6. Press the zoom key to deactivate electronic zoom.

**Active Cameos and Electronic ZOOM**

The ZOOM key takes the selected camera to a full-screen view from an active cameo. In a TRIPLEX mode screen, the active cameo can be moved to either a LIVE or a PLAY cameo.

---

*Note: As a result of this , if the ZOOM key is pressed while the active cameo is on a LIVE cameo, the display will be switched to a LIVE full screen display and the multiplexer will exit TRIPLEX mode.*

---

---

**HOW TO ELECTRONICALLY FREEZE AN IMAGE**



---

You can freeze the currently selected image whether in a full screen display or a multiscreen display. Whilst the image is frozen, **FRZ** will be displayed in a full screen display or \* in a multiscreen cameo.

**Freezing a full screen display:**

1. Press the freeze key  to freeze the display.
2. To unfreeze the image, press the freeze key again.

**Freezing a cameo in a multiscreen display**

1. Enter active cameo mode by pressing the enter key.
2. Use the arrow keys to move to the desired cameo.
3. Press the freeze key  to freeze the cameo.
4. To unfreeze the cameo, press the freeze key again.

Note that if the ALT key is pressed and the multiplexer is in ALT mode, then pressing the freeze key will emulate the VCR pause function. Ensure that the multiplexer is not in ALT mode (the led above the ALT key will be lit if ALT mode is active).

---

**HOW TO SELECT WHICH IMAGES ARE DISPLAYED BY WHICH MONITORS**

---

Your multiplexer has two monitor outputs designated A and B. The output for Monitor A is digital and allows you to view multiple images, zoom and freeze images etc. The output for Monitor B is analogue.

Monitor B always displays analogue live, full-screen images of the camera inputs, regardless of which mode is selected. When an alarm condition is encountered, Monitor B will display the camera associated with the alarm. Where several alarms are triggered, Monitor B will display the appropriate cameras in sequence.













Use the Monitor B key  to switch between Monitor A and Monitor B. The first keypress will transfer control to Monitor B; the next keypress will transfer control back to Monitor A.

---

**HOW TO CONTROL A VCR WITH AN RS232 INTERFACE USING YOUR MULTIPLEXER**

---

You can control the transport, record and play functions on your VCR from your multiplexer when it is connected via RS232. The keys used are shown below. The ALT key  has a toggle action. When pressed, the multiplexer enters ALT mode. The ALT key needs to be pressed again to exit ALT mode.

Function	Keypress
Stop	 + 
Record	 + 
Play	 + 
Pause	 + 
Rewind	 + Left Arrow
Fast Forward	 + Right Arrow
Frame Advance	 + Up Arrow
Frame Reverse	 + Down Arrow

---

**HOW TO SELECT VCR VIEW**

---

You can view the VCR output signal in order to check its output or settings. This is achieved by selecting the VCR output as an input source. Press the Function key (F) then the Play key (▶). The text **VCR** will be displayed on Monitor B. To deselect VCR input, press the Function and Play keys again.

---

**HOW TO ADJUST VCR PLAYBACK CONTRAST AND BRIGHTNESS**

---

You can adjust the brightness and contrast of the playback image (these settings do not affect the live or recorded image).

1. Select Play mode and start playing a previously recorded multiplexed tape in the VCR.
2. Call up the camera you wish to enhance onto monitor A full-screen by selecting the appropriate Camera key.
3. Use the Arrow keys to adjust the brightness and contrast. An adjustment scale will be superimposed over the image on monitor A. The scale will initially show the current level of adjustment or the default position. The default adjustment position is optimised during power up and may not be in the centre of the scale. Adjustments will be applied to the display of all the cameras when you return to the multiscreen display.

The up arrow increases the brightness and the down arrow decreases the brightness (asterisks \* show the level of brightness on the scale). The left arrow reduces the contrast and the right arrow increases the contrast (diamond symbols ◆ indicate the level of contrast on the scale).

---

**HOW TO CHANGE THE SIZE AND POSITION OF A PICTURE IN PICTURE (PIP) DISPLAY**

---

The Picture-In-Picture (PIP) format on Monitor A can be displayed in one of three sizes, and it can be displayed in one of two positions. The sizes can be 1/4, 1/9, or 1/16 of the full screen size. The PIP can either be displayed in the lower right hand corner of the display, or in the top left hand corner of the display.

The PIP size and position can be changed by using the arrow keys. The up and down arrow keys will change its position, and the left and right arrows will change its size. The left arrow key will make the picture smaller, the right will make the picture larger.

---

**HOW TO PLAY BACK A MACRO**

---

Your multiplexer may have up to 10 or 16 user-defined macros. Macros can contain up to 32 keystrokes and are programmed via the menu system. To run a macro, press the Function key (F) followed by the camera key (1 to 10 or 1 to 16) corresponding to the macro you want to run. While the macro is playing back, an **Fn** and the macro number is displayed on-screen. To stop a macro, press the Function key (F).

Your system may contain some macros that are designed to run automatically without your intervention (timed macros). Other macros may have been linked to certain alarm scenarios and will run each time the alarm occurs. See also **How to control a VCR using your multiplexer** on page 19.

---

**VCR PLAYBACK**

---

You must select the playback speed on the VCR, and not on the multiplexer. There is no related setup required on the multiplexer during playback. The multiplexer will automatically adjust its display to match the VCR playback speed.

**On-screen Indicators**

The on-screen indicator (**P024** for example, for 24 hour mode) tells you the speed at which the tape was recorded. It does not indicate the speed at which the tape is being played back. To find out the playback speed, you must look at the VCR's playback speed indicator. If the recording was made using the Camera Switch Input (R EXT), then the mode and speed indicator will read '**P EXT**'.

The **time and date** is displayed on-screen during PLAY mode. You should note, however, that this is the recorded time, not the current system time.

---

**VCR PLAYBACK**

---

If there was video loss at the time that the recording was made, the indicator, **V**, will be displayed in the corresponding camera cameo or **VDL**, if full-screen,

*Note: Any camera which is not detected on tape for eight or more consecutive cycles during playback, and is not flagged as a video loss camera, will result in the warning message, **N/A**, signifying that it is Not Available. This is a warning message only, and can appear during playback on full-screen or multiscreen formats on Monitor A.*

Several circumstances can cause an **N/A** indication. These are:

- 1) The camera may not have been included in the record list at the time of recording.
- 2) The camera may have been disabled at the time of recording.
- 3) The images for that camera on tape have been corrupted and cannot be decoded at the time of playback.
- 4) The VCR play speed is very slow.

The Not Available indicator, **N/A**, helps you to tell the difference between images which are not being updated during playback and images which are being updated from tape but have no movement within the image.

The alarm indicator, **A**, will be displayed with the corresponding camera image on Monitor A if there was an active alarm at the time that the recording was made.

### **When Tapes Cannot Be Decoded**

If the multiplexer cannot decode a tape which is being played back, the system will display a blank screen. The fields will not be decoded or separated.

---

**ALARM DISPLAYS**

---

### **Monitor A During Alarms**

During alarms in live mode, Monitor A will automatically switch to a preprogrammed, multiscreen alarm display, assuming that full screen alarm displays have not been specified. The alarm multiscreen includes not only the camera in alarm, but also associated cameras covering areas in or around the alarm area. The system automatically calls up a programmed custom quad display on Monitor A for a single alarm and optionally freezes the alarmed camera. The frozen camera will display a \* character, to indicate that it is frozen, and also display the indicator, **A**. For two simultaneous alarms, the two cameras in alarm and all of their associated cameras are displayed in a 10 way multiscreen. For three simultaneous alarms, the three cameras in alarm and two of their associated cameras are displayed in a 9 way multiscreen. If there are more than three alarms, then a 9 way multiscreen is displayed with up to 9 alarmed cameras. The remaining (unalarmed) cameos will simply show the unalarmed cameras in consecutive order.

### **Freezing Alarm Displays On Monitor A In Live Mode**

If the alarmed camera has not been frozen automatically, you can freeze all the cameras in the alarm display on Monitor A by pressing the Freeze key, or you can select an individual camera full screen and then freeze it.

### **Monitor B Full Screen During Alarms**

During alarms in LIVE mode, Monitor B will automatically switch to a display of the camera in alarm. If multiple alarms are active, the Monitor B will automatically sequence between the alarm cameras at a fixed 1 second dwell. This dwell is not programmable. Monitor B cannot freeze images.

*Note: The Monitor B screen will not revert to its original fixed display after the alarm is cleared. It will continue to display the last alarm camera. However, if sequencing was active on Monitor B before the alarm, then Monitor B will continue to sequence after the alarm is cleared.*

### **Alarm Displays In Play and TRIPLEX Mode**

Regardless of the mode selected, Monitor B will always display live images, and when an alarm occurs, is always switched to the camera in alarm.

In PLAY mode, when live alarm inputs occur, Monitor A will continue to display playback images and will not show the live alarms.

---

**ALARM DISPLAYS**

---

In TRIPLEX mode, an alarm indicator, **A**, will be displayed in a live cameo, providing the live cameo for the alarmed camera is currently being displayed.

**Monitor A During PLAY Mode and TRIPLEX Mode - Recorded Alarms**

Monitor A display will not automatically provide alarm displays based on recorded alarm status. Monitor A will display the playback images from the VCR according to your selected formats, and will display the normal **A** alarm indicator only if a camera was in alarm at the time that a recording was made.

*Note: If a camera which had an alarm at the time of recording is not selected by you for display, there will be no on-screen indication that the alarm occurred. Thus if you are looking for cameras in alarm during playback, ensure that all the cameras on tape are displayed on the multiscreen at once. There is an alarm buzzer on playback that sounds when an alarm flag is detected on tape. Ensuring that the buzzer is enabled will assist alarm detection during playback from tape.*

**Monitor B during PLAY Mode**

Monitor B will continue to display live images, according to your selection. If a live alarm occurs during play mode, then Monitor B will automatically switch to the camera in alarm. It will sequence at a 1 second dwell time for multiple cameras in alarm. After you have cancelled the alarm, Monitor B will continue to display the alarm camera which was on the screen at the time that the alarm was cancelled, or will continue to sequence if sequencing was enabled.

**Alarm LED And Internal Buzzer In PLAY Mode**

The LED and internal buzzer alarm indicators will sound, if enabled. The alarm buzzer has a different duty cycle so you can more easily identify it from the videoloss or playback buzzer. Note that the alarm buzzer may be disabled via the menu system.

**Alarm Indicators**

There is on-screen display of an **A** in each corresponding cameo of multiscreen displays and **ALM**, on any full-screen displays relating to cameras in alarm.

An additional indication, in the form of an LED, is provided on the front panel, next to the ALARM key. This LED will flash if any live alarm is active and has not been cleared. In addition, an internal buzzer will sound while any live alarm is active unless the buzzer has been disabled via the menu system..

---

**MOTION INDICATORS**

---

Depending how your system has been set up, the indicator, **M**, may appear in each camera scene whenever motion has been detected. This motion indicator will continue to be displayed on each active camera's cameo or monitor for at least 2 seconds after the motion has ceased.

---

**VIDEO LOSS**

---

Videoloss is indicated by **VDL** in a full screen display or **V** in the relevant cameo of a multiscreen display.

**Video loss Action In LIVE Mode**

Monitor A: If the camera is being displayed at the time that video loss occurs, the camera image will be frozen. However, if sequencing is in progress, the display will be blanked when it is switched to a camera experiencing video loss.

Monitor B: Monitor B cannot freeze images, and so the display will be blanked while a camera with video loss is selected.

**Video loss Action In RECORD Mode**

When video loss is detected, the affected camera is temporarily removed from the record list, and the coded digital data recorded with each field will be updated to indicate a video loss situation on the affected camera. This video loss status is then shown during playback. The multiplexer system continues to monitor cameras which have video loss and will automatically restore the cameras when video loss ceases.





**Baxall Security Limited**, Horsfield Way, Bredbury Park Industrial Estate, Stockport SK6 2SU, England.

Tel: 0161 406 6611 Fax: 0161 406 7677

Visit our Web site: <http://www.baxall.com>

Baxall Security Ltd. reserve the right to make changes to the product and specification of the product without prior notice to the customer.