

Videoswitch

VM-Series Multiplexer User Manual

Products covered by this manual:

Monochrome	4 Cameras	8 Cameras	12 Cameras	16 Cameras	20 Cameras
Simplex	VM-401M	VM-801M	VM-1201M	VM-1601M	VM-2001M
Mini Duplex <i>Plus</i>	VM-402M	VM-802M			
Duplex <i>Plus</i>	VM-403M	VM-803M	VM-1203M	VM-1603M	VM-2003M
Telemetry Duplex <i>Plus</i>	VM-404M	VM-804M	VM-1204M	VM-1604M	VM-2004M

Colour	4 Cameras	8 Cameras	12 Cameras	16 Cameras	20 Cameras
Simplex	VM-401C	VM-801C	VM-1201C	VM-1601C	VM-2001C
Mini Duplex <i>Plus</i>	VM-402C	VM-802C			
Duplex <i>Plus</i>	VM-403C	VM-803C	VM-1203C	VM-1603C	VM-2003C
Telemetry Duplex <i>Plus</i>	VM-404C	VM-804C	VM-1204C	VM-1604C	VM-2004C

Videoswitch
Units 15 & 16
Redfields Industrial Park
Redfields lane
Church Crookham
Hants GU52 0RD
England

Telephone 01252-851510
Fax 01252-851296
Email sales@videoswitch.co.uk
Web www.videoswitch.co.uk

Contents:

- 1. Getting Started3**
 - 1.1 Overview3
 - 1.2 Connecting Up3
 - 1.3 Interconnection Diagram4
- 2. Basic Operation5**
 - 2.1 Live Viewing5
 - 2.2 Recording5
 - 2.3 Playback5
- 3. The Front Panel Keys6**
 - 3.1 Front Panel Diagram7
 - 3.2 Primary Functions8
 - 3.2.1 Monitors A, B8
 - 3.2.2 PLAY8
 - 3.2.3 Cameras 1,2,3,4 etc.8
 - 3.2.4 Picture-in-Picture8
 - 3.2.5 Quad8
 - 3.2.6 Multi-Screens8
 - 3.2.7 Focus (Telemetry models only)8
 - 3.2.8 Zoom and Focus (Telemetry models only)8
 - 3.2.9 Joystick (Telemetry models only)9
 - 3.3 BLUE Functions9
 - 3.3.1 Enter Menu9
 - 3.3.2 Auto9
 - 3.3.3 Alarm9
 - 3.3.4 Freeze9
 - 3.3.5 Digital Zoom9
 - 3.3.6 Iris (Telemetry models only)9
 - 3.3.7 Presets (Telemetry models only)9
 - 3.3.8 Auxiliaries (Telemetry models only)9
 - 3.3.9 Telemetry controls which Camera?9
 - 3.4 MENU Functions10
 - 3.4.1 Back10
 - 3.4.2 Select10
 - 3.4.3 Default10
 - 3.4.4 Up10
 - 3.4.5 Down10
 - 3.4.6 Left11
 - 3.4.7 Right11
- 4. Status Information12**
 - 4.1 Time, Date and Day of Week12
 - 4.2 Titles12
 - 4.2.1 Multiplexer Title12
 - 4.2.2 Cameras Titles12
 - 4.3 Status Information12
 - 4.3.1 Time Windows12
 - 4.3.2 Alarms12
 - 4.3.3 Sequencing12
 - 4.3.4 Time-Lapse Mode12
- 5. The Menus13**
 - 5.1 Passwords13
 - 5.2 User Menu13
 - 5.3 Installer Menu15
 - 5.4 Manager Menu19
- 6. Specifications20**
 - 6.1 Frame Stores20
 - 6.1.1 Multiplexing Update Rate (PAL)20
 - 6.1.2 Resolution (PAL)20
 - 6.2 Inputs/Outputs20
 - 6.2.1 Video20
 - 6.2.2 VCR Sync20
 - 6.2.3 Dome20
 - 6.2.4 Twisted Pair Telemetry20
 - 6.2.5 Co-Ax Telemetry20
 - 6.2.6 Remote Control20
 - 6.2.7 Alarm Inputs20
 - 6.2.8 Alarm Relay Contacts20
 - 6.3 Connector Pin-Outs20
 - 6.3.1 Alarm Connector20
 - 6.3.2 Remote Connector21
 - 6.4 Power21
 - 6.4.1 DC Power21
 - 6.4.2 AC Power (via main adapter provided)21
 - 6.5 Physical and Environmental21
 - 6.5.1 Unit Dimensions21
 - 6.5.2 Packaged Dimensions21
 - 6.5.3 Weights21
 - 6.5.4 Operating Temperature21
 - 6.5.5 Storage Temperature21
 - 6.5.6 Humidity21
 - 6.5.7 Ventilation21

1. Getting Started

1.1 Overview

Congratulations on choosing a Videoswitch multiplexer. This product combines ease-of-use with high image quality and reliability. Basic day-to-day operation is performed by one-press operation of the front panel keys. Configuration of the multiplexer is accomplished by entering the easy-to-use password protected menus.

1.2 Connecting Up

This table indicates what each connector on rear panel of the multiplexer should be connected to. Note that in all installations some connections are essential. Others are optional, depending on whether you require special facilities such as alarms, automatic time lapse mode switching and remote control.

Connector identification on Rear Panel of Multiplexer	What to connect it to...	Connecting cable required	Essential in most systems?
CAMERA "1"	a Colour or Monochrome Camera	BNC to BNC	Yes
CAMERA "2"	a Colour or Monochrome Camera	BNC to BNC	Yes
CAMERA "3"	a Colour or Monochrome Camera	BNC to BNC	Optional
CAMERA "4"	a Colour or Monochrome Camera	BNC to BNC	Optional
...etc	...etc	...etc	Optional
MONITOR "A"	Monitor (main control monitor)	BNC to BNC	Yes
MONITOR "B"	Monitor (public display monitor or secondary control monitor)	BNC to BNC	Optional
VCR "PLAY"	Connect to VCR's video Output	BNC to BNC	Yes
VCR "RECORD"	Connect to VCR's video Input	BNC to BNC	Yes
"12V DC 2A"	Connect to Videoswitch 12V dc, 2Amp power supply (PSU)	Attached to PSU (provided)	Yes
"VCR SYNC"	Connect to VCR's "Camera Switch" or "Sync" terminal	Phono to single wire (provided)	Preferred, so that time-lapse configuration is automatic.
"ALARMS"	Connect inputs to PIR detectors or other devices with volt-free contacts.	25-way D-type Male to twisted pairs	Optional
"ALARMS"	Connect alarm relay output contacts to VCR's time-lapse mode control input	25-way D-type Male to 3 single wires	Optional
"REMOTE"	VK-3201 or VK-3202 Remote keyboard, or to Computer	Male 9-way D-type to Female 9-way D-type	If remote keyboard is required
"e-BUS"	Do not connect to anything! This is used for factory software upgrades.	none	No

1.3 Interconnection Diagram

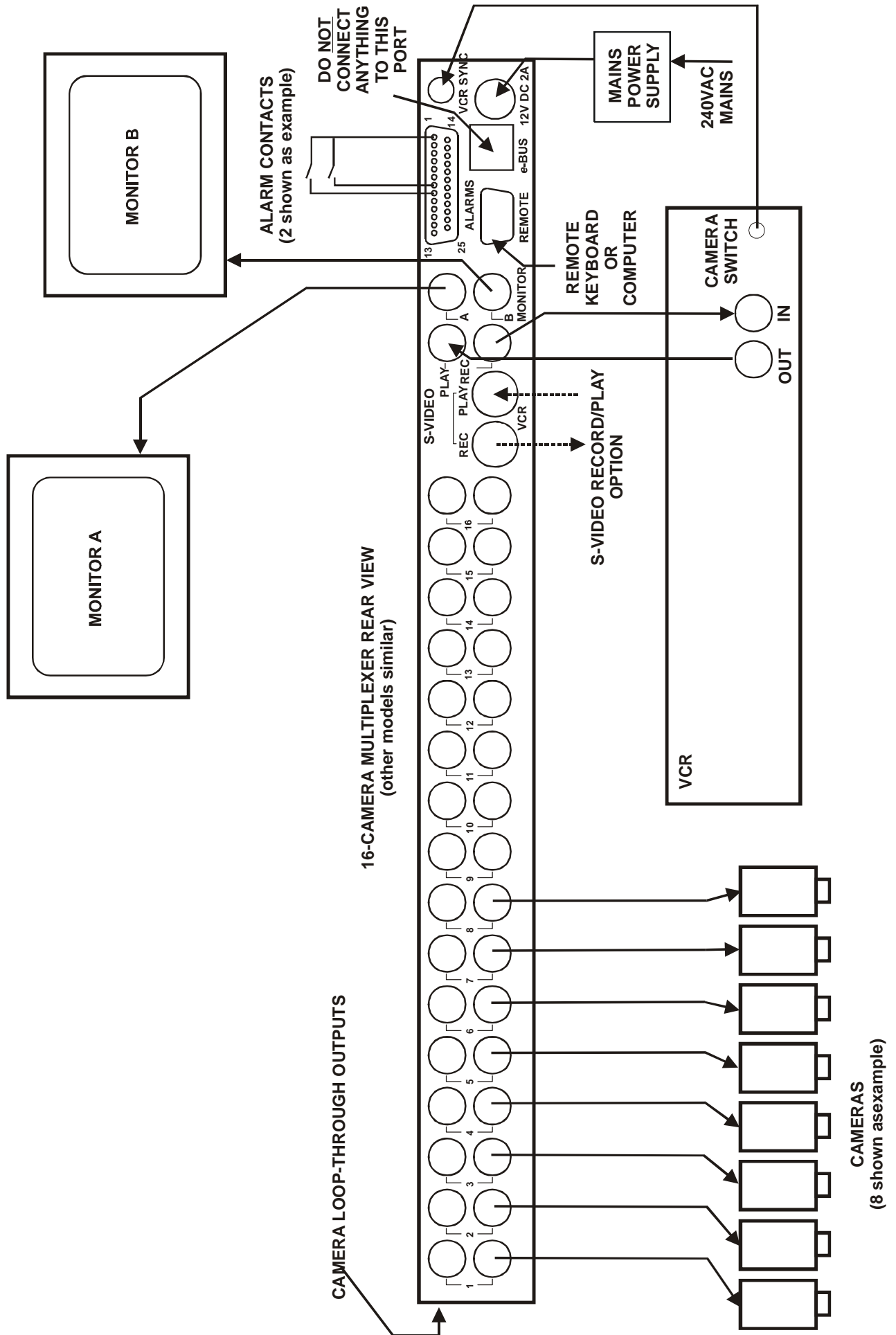

2. Basic Operation

2.1 Live Viewing

One or both monitors may be used for live viewing, with various combinations of full screen images and multi-screen images displayed on the two monitors (Simplex models always display full screen images in live mode).

- Select which monitor you wish to view by pressing "MONITOR A" or "MONITOR B" keys (not applicable to Simplex models).
- Press the camera keys identified as "1", "2", "3", "4" etc. to select a full screen image of a camera on the selected monitor.
- Press the "PIP", "QUAD" or "MULT-SCREEN" keys to see multiple cameras images on the selected monitor (not applicable to Simplex models)

2.2 Recording

When the VCR and multiplexer are both in "RECORD" mode, images from *all* the cameras will be continuously recorded onto tape. Irrespective of what is being displayed on the monitors, the system will always record *full* screen images onto tape, providing maximum recorded image quality. This is the primary purpose of a video multiplexer.

- The multiplexer is normally in RECORD. If the word "PLAY" is displayed on monitor "A", press the "PLAY" key momentarily to return to RECORD mode. The VCR is put in record mode by pressing its "REC" button (refer to VCR's manual for details).
- The time lapse mode of the VCR must be set. Typically the 24 hour mode or 27 hour mode is selected which means that a 180 minute VHS tape will last for a whole 24 hour period (refer to VCR's manual for details).
- If a "VCR Sync" cable is used, the time lapse mode of the multiplexer is set automatically. Otherwise the time lapse mode of the multiplexer must be set to match that of the VCR (via the Installer menu).

2.3 Playback

Both the VCR and the multiplexer must be in "PLAY" mode in order to play back recordings.

- To put the multiplexer into PLAY mode, press its PLAY key and keep it pressed for about one second until the word "PLAY" appears on Monitor "A".
- To put the VCR into play mode press its "PLAY" key (refer to VCR's manual for details).
- Playback is always on monitor "A" and may optionally be on monitor "B" also (refer to configuration section)
- When the system is playing back recorded images, the full screen image from any of the cameras may be selected.
- If you wish to see more than one camera image at a time, press the "PIP", "QUAD" or "MULT-SCREEN" keys as required.
- Remember to routinely play back tapes to verify the correct functioning of the whole system.

3. The Front Panel Keys

- The primary functions of the front panel keys allow the various display and record/play modes of the multiplexer to be selected.
- Some keys have secondary “Blue Functions”. These additional facilities are accessed either by pressing and holding the BLUE key and then pressing another key, or by momentarily pressing the BLUE key, and then pressing another key within 2 seconds.
- When the menus are entered (BLUE + MONITOR “A”), some of the keys then assume menu control functions, i.e. SELECT, BACK, ← → ↑ ↓ and DEFAULT (PLAY key)

3.1 Front Panel Diagram

VM-800 Series MULTIPLEXER FRONT PANEL
(other compact models are similar)

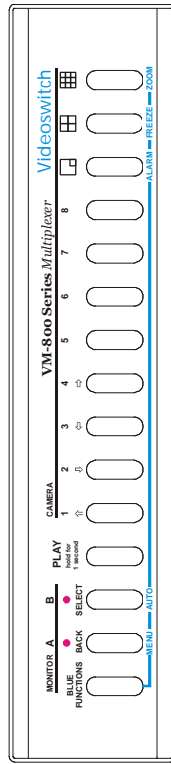

VM-2000 Series MULTIPLEXER FRONT PANEL
(other 19" models are similar)

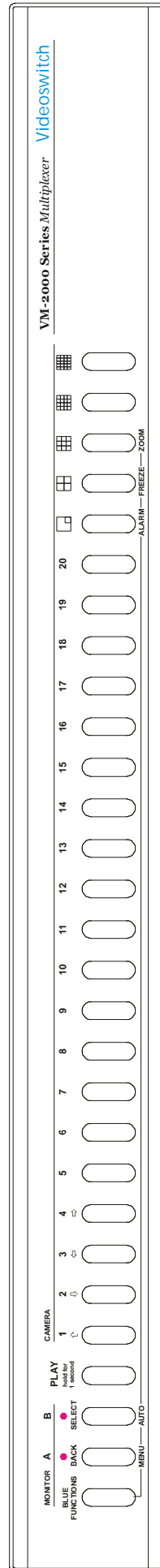

3.2 Primary Functions

3.2.1 Monitors A, B

Press the Monitor "A" key to select that monitor. The "Camera", "Picture-in-Picture", "Quad" and "Multi-Screen" keys may be then pressed to call up an image on monitor "A".

If you now press Monitor "B", the same "Camera", "Picture-in-Picture", "Quad" and "Multi-Screen" keys may be then be used to call up a different image on monitor "B".

Note that although the two monitors can display different image formats, not all combinations are possible. If an image is selected on one monitor that cannot be displayed simultaneously with the image being displayed on the other monitor, the other monitor will revert to full screen display (refer to user menu for mode locking). For example, it is not possible to display two different *full* screen images (in RECORD mode), whereas is is possible to display two different quads, a Quad and a PIP or a full screen image and any different type of screen image.

3.2.2 PLAY

This key is used to switch between RECORD and PLAY modes. This key must be pressed and held for about one second in order to select PLAY mode. This feature is to prevent accidental interruption to the normal recording process. Selection of PLAY mode may be prohibited by means of a Manager Menu option for added safety.

3.2.3 Cameras 1,2,3,4 etc.

The camera keys are used to select a full screen image of any of the cameras on the currently selected monitor.

3.2.4 Picture-in-Picture

This key selects Picture-in-Picture (PIP) mode in which a small image of one of the cameras is displayed in a corner of the screen, whilst the rest of the screen display the image from another camera. Before selecting PIP, select the full screen image of the camera that you want in the PIP. After selecting PIP mode, us the Camera 1,2,3,4 etc keys to change the main image. Press the PIP key again to revert to normal full screen mode.

3.2.5 Quad

Press the QUAD key to display cameras 1, 2, 3 and 4 on the currently selected monitor. For multiplexers with more than four camera inputs, this key may be pressed again to display different groups of four cameras. Note that a different quad may be displayed on each monitor.

3.2.6 Multi-Screens

Multiplexers with more than four cameras are provide with one or more MULTI-SCREEN keys. The various models can display multi-screen images as follows. Press the MULTI-SCREEN keys again to select different options:

Models	Quad	x8	x9	x12	x16	x20
4 Cameras	✓					
8 Cameras	✓	✓				
12 Cameras	✓	✓		✓		
16 Cameras	✓	✓			✓	
20 Cameras	✓		✓		✓	✓

3.2.7 Focus (Telemetry models only)

Multiplexers with telemetry and dome support have keys to control the Focus of a camera that is either within a dome or is controlled by a Videoswitch telemetry receiver. To revert to auto-focus, press the camera select key again (1,2,3 etc).

3.2.8 Zoom and Focus (Telemetry models only)

Multiplexers with telemetry and dome support have keys to control the Zoom and Focus of a camera that is either within a dome or is controlled by a Videoswitch telemetry receiver

3.2.9 Joystick (Telemetry models only)

Multiplexers with telemetry and dome support have a joystick. This is used to move a camera either in a dome, or on a pan and tilt head controlled by a Videoswitch receiver. Note that the camera that is controlled is the one last selected for display as a full screen analogue image.

3.3 BLUE Functions

3.3.1 Enter Menu

To enter the menu system, press the BLUE key and the Monitor "A" key. See section 3.3.10 for the "MENU keys" that become available once you have entered the menu system.

3.3.2 VCR Direct View

Press the BLUE key and the PLAY key to enter VCR Direct view mode (not available if coverts are enabled). The output of the VCR will be displayed. This mode is useful for setting up the VCR menu and, during installation, for checking VCR connections. If the VCR is in LIVE mode, rapidly multiplexing images should be seen. If the VCR is in PLAY mode, then whatever is being played back from the tape will be displayed.

3.3.3 Auto

Press the BLUE key and the Monitor "B" key. The word "SEQ" will appear on the currently selected monitor. If a *full screen* image is being displayed, then full screen images will sequence. If a *quad* image is being displayed when you enter Auto Sequence mode, then different available quads will sequence. The cameras that are included, the dwell time and the mode (random or sequential) may be modified from within the menus. To cancel sequencing, press BLUE and Monitor "B" again.

3.3.4 Alarm

Press the BLUE key and the PIP key to lockout alarms, indicated by a key symbol on Monitor "A". Alarm lockout is a convenience feature that prevents alarms from changing screen modes while you are manual controlling the multiplexer.

3.3.5 Freeze

Press the BLUE key and the QUAD key to digitally freeze the image (RECORD or PLAY mode).

3.3.6 Digital Zoom

Press the BLUE key and the MULTI-SCREEN key to digitally enlarge an image. Camera keys "1", "2", "3" and "4" (also identified by as \leftarrow \rightarrow \uparrow \downarrow) may then be used to select different parts of the enlarged image.

3.3.7 Iris (Telemetry models only)

Press the BLUE key and move the joystick up or down to control the iris (if applicable). To revert to auto-iris, press the camera select key again (1,2,3 etc).

3.3.8 Presets (Telemetry models only)

Press the BLUE key and on of the Cameras keys "1", "2", "3" etc to call up a preset position on a dome camera or pan and tilt head. A User menu option specifies whether a single preset or a group of presets (for a preset tour) may be selected.

3.3.9 Auxiliaries (Telemetry models only)

Press the BLUE key and one of the FOCUS or ZOOM keys to operate auxiliary relays on a telemetry receiver. The following auxiliary functions are available:

Auxiliary	Type	Normal Use	Key
1	Latched	Lamp	FOCUS (left)
2	Latched	Receiver Alarm Enable	FOCUS (right)
3	Latched	Wipe	ZOOM (left)
4	Momentary	Wash	ZOOM (left) - press and hold
5	Latched	Auto-Pan / Tour	ZOOM (right)

3.3.10 Telemetry controls which Camera?

Telemetry functions operate on the camera that is currently being displayed as a full screen analogue image. It is suggested that the display mode for monitor A is analogue when telemetry is used. Refer to User menu. Telemetry is not available in PLAY mode.

3.4 MENU Functions

Once you have entered the menu system (BLUE key + Monitor "A" key), the following keys are the only ones that are used to navigate within the menus and to select the various configuration options. Note that the bottom line of text on the menu screen indicates which keys can be used. Menus are displayed on monitor "A" only.

The most important menu keys are \uparrow \downarrow , SELECT and BACK.

3.4.1 Back

This key (also identified as the Monitor "A" key) is used to come back a step from wherever you are in the menu system.

- When have selected the option you require in a particular part of the menu system, press the BACK key to return to where you were.
- If you are right at the start of the menu, pressing the BACK key will cause you exit the menu system altogether.

3.4.2 Select

The key (also identified as the Monitor "B" key) is used to:

- select a sub-menu and takes you deeper into the menu system. If you have pressed SELECT to look at a sub-menu or change a setting, you may press BACK to return
- move on to the next character or digit when setting time, date, numeric values or text

3.4.3 Default

This key (identified as the "PLAY" key) must be pressed and held for a second in order to act.

It is a very convenient way to set individual menu options to their default value and to turn groups of settings on or off. For example, depending where you are in the menu system, it is used to:

- Go to top of a menu
- Select the default option in a list
- Select a default numeric value (e.g. set a dwell time to 1)
- Clear a camera Title
- Turn all the activity zones *on* or *off*
- Where a line of dashes and blocks are displayed (e.g. cameras to be auto sequenced), this key will set them all *on* or *off* in one key press..

Where ever you are in the menu, if you do not know what something should be set to, press this DEFAULT key.

3.4.4 Up

The \uparrow key (also identified as the Cameras "1" key) has a number of function depending on where you are in the menu:

- Move up through a list of menu items to select the one you require
- Increment a numeric value (such as a dwell time, password, time or date)
- Move up to select individual motion detect zones
- Increment motion detection sensitivity
- Move the position of the date/time or a title upwards

3.4.5 Down

The \downarrow key (also identified as the Cameras "2" key) has a number of function depending on where you are in the menu:

- Move down through a list of menu items to select the one you require
- Decrement a numeric value (such as a dwell time, password, time or date)
- Move down to select individual motion detect zones
- Increment motion detection sensitivity

- Move the position of the date/time or a title downwards

3.4.6 Left

The ⇐ key (also identified as the Cameras “3” key) is used to:

- Move to a different digit when setting a multiple digit number, time or date
- Select which dash or block you want to modify (e.g. cameras to be auto sequenced),
- Select which character you wish to modify when editing a camera title
- Move the position of the date/time or a title to the left

3.4.7 Right

The ⇒ key (also identified as the Cameras “4” key) is used to:

- Move to a different digit when setting a multiple digit number, time or date
- Select which dash or block you want to modify (e.g. cameras to be auto sequenced),
- Select which character you wish to modify when editing a camera title
- Move the position of the date/time or a title to the right

4. Status Information

The monitor display information that helps you use the multiplexer. Some of this information may be turned off in the menus.

4.1 Time, Date and Day of Week

If the internal clock is to be used for time-stamping of recorded images, the time and date is also displayed on Monitor "A". Remember to disable the time and date display on the VCR otherwise you may have two sets of information recorded onto tape.

4.2 Titles

4.2.1 Multiplexer Title

A sixteen character title may be enter via the Installer menu to identify the multiplexer. This title may be recorded onto tape if required.

4.2.2 Cameras Titles

Each camera may have a sixteen character title associated with it that is displayed on the screen. These title are not stored onto tape, but will be displayed when the tape is replayed.

If titles are too long to be displayed in certain multi-screen modes, they will automatically be replaced on the screen with the cameras number.

4.3 Status Information

The following status information may be displayed (only on monitor "A" unless otherwise stated):

4.3.1 Time Windows

A clock symbol is displayed if the current time and day of week does not lie within a time window. This is relevant if activity detection or alarm inputs have be set-up to operate within time windows. In this case, it means that the multiplexer will not respond to alarms when the clock symbol is being displayed.

4.3.2 Alarms

If an activity detection or an alarm contact alarm is occurring, the text "ALM" will appear on the screen.

If you have locked out the alarms, a key symbol followed by "AL" will be displayed. This indicates that the multiplexer will not currently respond to any alarms.

4.3.3 Sequencing

The word "SEQ" will appear if auto sequencing is currently in process. This can appear on both monitors.

4.3.4 Time-Lapse Mode

In RECORD mode, the time lapse mode that the multiplexer is operating in is displayed (e.g. 24 hr). If the multiplexing is automatically detecting the time lapse mode from the "VCR Sync" signal, it will display an arrow in a diamond symbol in front of the time lapse mode. This confirms that the sync pulse is being detected properly.

5. The Menus

This multiplexer is provided with a comprehensive but easy to use menu system. The menus are divided in three different sections, each of which may be password protected:

- User Menu - this deals with mainly with display options
- Installer - most of the detailed configuration is performed in this menu
- Manager - this menu provides protected access to covert cameras

5.1 Passwords

Up to three different passwords may be set (each is a six digit number). A password that is set to "000000" allows free access.

The first password to set is the Manager password, and this is set in Manager menu. This password will allow access to all three menus. Set this password to zero if you want no password protection at all.

If you want separate password protection for the installer menu, a second password may be set in the installer menu. This password will allow access to the installer and user menus.

If you want a third password for the user menu, a password may be set in the user menu. This password will allow access to the installer menu only.

When a menu is locked by a password, a key symbol is displayed adjacent to the menu name when you first enter the menu system. If you press SELECT to enter a password protected menu, you will need to enter a password. When you have entered a password, you will be granted access to the permitted menus. If you exit the menu system altogether but then re-enter them within 30 seconds, you do not have to key in the password again.

5.2 User Menu

The options appearing in this menu are shown in this table. Note that some options are not applicable to all multiplexer models. Press and hold the PLAY key to set any option to its default state.

Sub-Menus & Options	Press SELECT to enter option, then do the following:
Set Time HH:MM:SS	Set the date using ← → ↑ ↓. Press BACK to finish.
Set Date DD/MM/YY	Set the time using ← → ↑ ↓. Press BACK to finish.
Full Screen Display Mode	
Monitor A	The full screen may be either Analogue for best resolution and refresh speed, or digital for zero bounce on switching. Use ↑ ↓. Press BACK to finish.
Monitor B	The full screen may be either Analogue for best resolution and refresh speed, or digital for zero bounce on switching. Use ↑ ↓. Press BACK to finish.
Display Mode Locking	This option allows display modes to be locked such that selection of a conflicting mode on the other monitor is prevented. Use ↑ ↓. Press BACK to finish.
Multi-Screen Anti-Flicker	Set anti-flicker mode if shimmering effects are obtrusive on the multi-screen images. Use ↑ ↓. Press BACK to finish.
Picture in Picture	
PIP Position	Set the PIP position using ↑ ↓. Press BACK to finish.
PIP Selection/Sequencing	Use ↑ ↓ keys to select whether Camera 1,2, 3 etc keys affect the main image or the PIP image. Also affects which one auto sequences. Press BACK to finish.
Monitor A Auto Sequencing	
Camera List	Select which cameras are to be included in the sequencing using ↑ ↓ and SELECT. Press BACK to finish.
Random Sequencing	Full screen sequencing may be set to random mode

	here using \uparrow \downarrow . Press BACK to finish.
Full Screen Dwell Times	
Camera 1,2,3 etc	Set the required camera using \uparrow \downarrow , then press ENTER to continue or BACK to finish.
Full-Screen Dwell Time	Set the dwell time using \uparrow \downarrow . Press BACK to finish.
Multi-Screen Dwell Time	For multiplexer with more than 4 cameras, Quads may be sequenced. With 16 camera multiplexers, the 8-way multi-screens may be sequenced. Set the dwell time using \uparrow \downarrow . Press BACK to finish.
Monitor B Auto Sequencing	
Camera List	Select which cameras are to be included in the sequencing using \uparrow \downarrow and SELECT. Press BACK to finish.
Random Sequencing	Full screen sequencing may be set to random mode here using \uparrow \downarrow . Press BACK to finish.
Full Screen Dwell Times	
Camera 1,2,3 etc	Select the required camera using \uparrow \downarrow , then press ENTER to continue or BACK to finish.
Full-Screen Dwell Time	Set the dwell time using \uparrow \downarrow . Press BACK to finish.
Multi-Screen Dwell Time	For multiplexer with more than 4 cameras, Quads may be sequenced. With 16 camera multiplexers, the 8-way multi-screens may be sequenced. Set the dwell time using \uparrow \downarrow . Press BACK to finish.
Change User Password	The user password may be set here. Set to "000000" if you want to allow free access. Use \leftarrow \rightarrow \uparrow \downarrow and SELECT. Press BACK to finish.

5.3 Installer Menu

The options appearing in this menu are shown in this table. Note that some options are not applicable to all multiplexer models. Press and hold the PLAY key to set any option to its default state.

Sub-Menus & Options	Press SELECT to enter option, then do the following:
Time Lapse Modes	
Normal	Select the time-lapse mode required when there is <i>not</i> an alarm using \uparrow \downarrow . Press BACK to finish.
Alarm	Select the time-lapse mode required when there <i>is</i> an alarm using \uparrow \downarrow . Press BACK to finish.
Special Multiplex Options	
VCR Sampling Mode	Use this option to specify whether an older Sony or Sanyo VCR is being used with irregular field sampling. Use \uparrow \downarrow . Press BACK to finish.
VCR Sync Input	Some VCR sync outputs require a pull-up resistor. If the multiplexer is not detecting the sync pulse, try each option using \uparrow \downarrow . Press BACK to finish.
Alarm Prioritised	Using \uparrow \downarrow to select prioritised alarm recording. Any cameras with alarms will be recorded more frequently if this mode is selected. Note that multi-screen update may be affected, particularly in PLAY mode, Select full screen for maximum update rate. Press BACK to finish.
Play-Back Compatibility	Compatibility with older Series 1 monochrome multiplexer may be selected here using \uparrow \downarrow . Press BACK to finish.
Custom Multiplex - Normal	
Custom Multiplex - Alarm	
S-Video Record/Play	S-Video record and playback compatibility is selected here using \uparrow \downarrow . Press BACK to finish.
Multiplexer Title	The multiplexer title is set character by character using \leftarrow \rightarrow \uparrow \downarrow and SELECT. Press BACK to finish.
Camera Titles	
Camera 1,2,3 etc	Select the required camera using \uparrow \downarrow , then press ENTER to continue or BACK to finish.
Title	Camera titles are set character by character using \leftarrow \rightarrow \uparrow \downarrow and SELECT. Press BACK to finish.
Text Options	
Date/Time Formats	The date and time formats may be set to suit your preference, Set to <i>off</i> if you wish to use the VCRs internal date and timer generator. Use \leftarrow \rightarrow \uparrow \downarrow and SELECT. Press BACK to finish.
Show Day of Week	The day of week may optionally be displayed. Select here using \uparrow \downarrow . Press BACK to finish.
Show Text on Monitor B	Text is always displayed on monitor "A" but may optionally be displayed on monitor "B" as well. Use \uparrow \downarrow . Press BACK to finish.
Hide Multi-Screen Titles	Titles may be suppressed in multi-screen displays in order to reduce screen clutter. Use \uparrow \downarrow . Press BACK to finish.
Text Positions	text position may be altered, but make sure that they do not overlap.
Date/Time	The date and time may be displayed anywhere on the screen. Use \leftarrow \rightarrow \uparrow \downarrow . Press BACK to finish.
Multiplexer Title	The multiplexer title may be displayed anywhere on the screen. Use \leftarrow \rightarrow \uparrow \downarrow . Press BACK to finish.
Camera Title	The camera title (full screen) may be displayed anywhere on the screen. Use \leftarrow \rightarrow \uparrow \downarrow . Press BACK to finish.

Status Info	The status information may be displayed anywhere on the screen. Use \leftarrow \rightarrow \uparrow \downarrow . Press BACK to finish.
Text Style	The style of all text character may be selected for optimum clarity and personal preference. Use \uparrow \downarrow . Press BACK to finish.
Alarms/Activity Detection	
Activity Detection	
Camera 1,2,3 etc	Select the required camera using \uparrow \downarrow , then press ENTER to continue or BACK to finish.
Zones	Select which parts of the image you wish to be monitored for activity. Use \leftarrow \rightarrow \uparrow \downarrow and SELECT. PLAY will turn all zones on or off. Press BACK to finish.
Test	The activity detection is tested here. Use \uparrow \downarrow to select sensitivity and \leftarrow \rightarrow to select what area of the screen must have activity in order to trigger an alarm, as shown by "AL" on the screen. Press BACK to finish.
Daily Timers	Timer may be set for each day of the week to control when activity detection or alarm contact inputs are active.
Monday, Tuesday etc	Select the required day using \uparrow \downarrow , then press ENTER to continue or BACK to finish.
Start Time	Set the start time for this day of the week. Use \leftarrow \rightarrow \uparrow \downarrow and SELECT. Press BACK to finish.
End Time	Set the end time for this day of the week. Use \leftarrow \rightarrow \uparrow \downarrow and SELECT. Press BACK to finish.
Activity Enabled	Activity detection may be enabled, disabled or controlled by the daily timers. Use \uparrow \downarrow . Press BACK to finish.
Alarm Input Enabled	Alarm inputs may be enabled, disabled or controlled by the daily timers. Use \uparrow \downarrow . Press BACK to finish.
Alarm Input Polarity	Alarm inputs may be set as normally open or normally closed. Use \leftarrow \rightarrow \uparrow \downarrow SELECT. Press BACK to finish.
Pull-Up on Alarm/Activity	
Full Screen Pull-Up	Specify whether you want alarms to pull up a full screen image. Use \uparrow \downarrow . Press BACK to finish.
Pull-Up Hold Time	Specify how long you want a pulled-up full screen image to be held before anything else can be displayed. Use \uparrow \downarrow . Press BACK to finish.
Pull-Up Sequence Dwell Time	Specify how long you want each pulled-up full screen image to be held when cycling between more than one alarmed camera. Use \uparrow \downarrow . Press BACK to finish.
Preset on Alarm/Activity	
Alarm Relay Hold Time	Specify how long you the alarm relay to stay energised when alarms have cleared. The alarm time lapse mode is also selected while the relay is operating. Use \uparrow \downarrow . Press BACK to finish.
Dome/Receiver Type	Specify the type of dome or receiver that is to be controlled by twisted pair. Dome types may not be mixed, but any dome type may be mixed with coax-receivers. Use \uparrow \downarrow . Press BACK to finish.
Coax Receivers	Specify which cameras, if any, have VR receivers using coax telemetry control. Use \leftarrow \rightarrow \uparrow \downarrow SELECT. Press PLAY to toggle all on or off. Press BACK to finish.
Receiver/Dome Setup	Note that some options do not apply to certain domes.
Camera 1,2,3 etc	Select the required camera using \uparrow \downarrow , then press ENTER to continue or BACK to finish. Use \uparrow \downarrow . Press BACK to finish.
Configure Receiver/Dome	

Auto Colour/Mono	The mode or mono/colour switching cameras may be set here. Note that OFF toggles colour/mono while ON sets camera to AUTO.
Zoom Rate	The rate of zoom may be programmed here using \leftarrow \rightarrow . Press BACK to finish.
Focus Rate	The rate of focus may be programmed here using \leftarrow \rightarrow . Press BACK to finish.
Iris Rate	The rate of iris may be programmed here using \leftarrow \rightarrow . Press BACK to finish.
User Command	Additional dome commands may be programmed here in hexadecimal. Use \leftarrow \rightarrow \uparrow \downarrow SELECT and BACK.
Receiver Video Gain	The video gain of a receiver may be set here using \leftarrow \rightarrow . If control of receiver is lost, set gain to appropriate level and wait up to 30s to regain control. Press BACK to finish
Receiver Video Lift	The high frequency lift (compensation) of a receiver may be set here using \leftarrow \rightarrow . Wait up to 30s for lift wo reach required setting. Press BACK to finish.
VP-1/VP-1A Preset Dwell	Press ENTER to start timer. Press BACK when required preset dwell time has elapsed.
VP-1A Alarm Dwell	Press ENTER to start timer. Press BACK when required alarm dwell time has elapsed.
VR Receiver Training	Press ENTER to start receiver training. Press BACK when complete.
Program Presets	Store the current camera position as a preset in a dome or telemetry receiver. Use \uparrow \downarrow . Press SET to store preset. Press BACK to finish.
Program Tour	A tour may be programmed here. After exiting the menu, use AUX5 to invoke the tour.
Create New Tour	Press SEL then use \uparrow \downarrow to select a preset. Press SEL again. Press BACK to finish.
Dwell	Specify how long you want this preset to be held in the tour. Use \uparrow \downarrow . Press BACK to finish.
Pan Rate	The pan speed between presets may be programmed here using \leftarrow \rightarrow . Press BACK to finish.
Tilt Rate	The tilt speed between presets may be programmed here using \leftarrow \rightarrow . Press BACK to finish.
Add to tour?	Press SEL to add this preset to the tour. Press BACK to finish.
Power-up States	Following a power loss, the the display mode and PLAY mode may be specified.
Monitor A	
Display Mode	Select the display mode you require following power up. Use \uparrow \downarrow . Press BACK to finish.
Full Screen Camera	Select the full screen camera you require (if applicable) following power up. Use \uparrow \downarrow . Press BACK to finish.
Auto Sequencing	Specify whether you want auto sequencing following power up. Use \uparrow \downarrow . Press BACK to finish.
Monitor B	
Display Mode	Select the display mode you require following power up. Use \uparrow \downarrow . Press BACK to finish.
Full Screen Camera	Select the full screen camera you require (if applicable) following power up. Use \uparrow \downarrow . Press BACK to finish.
Auto Sequencing	Specify whether you want auto sequencing following power up. Use \uparrow \downarrow . Press BACK to finish.
Picture in Picture Camera	Select the PIP camera you require (if applicable) following the power up. Use \uparrow \downarrow . Press BACK to finish.
Play Mode	Specify whether you want the multiplexer to go into PLAY mode following power up. Use \uparrow \downarrow . Press BACK to finish.

Camera Termination	The 75 Ohm camera terminations may be individually turned on or off here. Use ⬅ ➡ ⬆ ⬇ SELECT. Press BACK to finish.
Camera Brightness	
Camera 1,2,3 etc	Select the required camera using ⬆ ⬇, then press ENTER to continue or BACK to finish.
Digital Full/Multi/Record	The input gain may be varied to adjust the brightness of the digital full screen, the multip-screens and the recorded images. It is preferable to leave at the default setting and to ensure that the camera is properly adjusted. Use ⬅ ➡ and BACK to finish.
Analogue Full Screen	The brightness of the analogue full-screen images may be adjusted here. It is preferable to leave at the default setting and to ensure that the camera is properly adjusted. Use ⬅ ➡ and BACK to finish.
Playback Brightness	The playback gain may be varied to adjust the playback brightness. Use ⬅ ➡ and BACK to finish.
Remote Keyboard	
Address of this Multiplexer	If several multiplexers are to be controlled by a single remote keyboard, they must be assigned different addresses. Use ⬆ ⬇. Press BACK to finish.
Interface Type	A remote keyboard uses RS485. Computer control will probably use RS232. Use ⬆ ⬇. Press BACK to finish.
Test Mode	When ON, communication errors will be displayed on the main monitor. This is useful for testing remote control by non-Videoswitch equipment. Use ⬆ ⬇. Press BACK to finish.
Colour/Greyscale Test Bars	Colour or Greyscale test bars may be set here for testing or adjusting monitors etc.
Factory Defaults	
Restore Factory Defaults	This allows you to set all options in the multiplexer to the factory defaults. Note that camera titles and passwords are <i>not</i> cleared. Use ⬆ ⬇. Press BACK to finish.
Reset Camera Titles	This allows you to reset all the camera titles to "Camera1", "Camera2" etc. Use ⬆ ⬇. Press BACK to finish.
Change Installer Password	The installer password may be set here. Set to "000000" if you want to allow free access. Use ⬅ ➡ ⬆ ⬇ and SELECT. Press BACK to finish.

5.4 Manager Menu

The options appearing in this menu are shown in this table. Note that some options are not applicable to all multiplexer models. Press and hold the PLAY key to set any option to its default state.

Sub-Menus & Options	Press SELECT to enter option, then do the following:
Playback Permission	Play back may be locked out completely or restricted to Monitor B. Use \uparrow \downarrow and press BACK to finish.
Covert Permission	Permission to view coverts during playback is set here. Use \uparrow \downarrow . Press BACK to finish.
Covert Camera List	Specify which cameras are to be covert (hidden) using \uparrow \downarrow and SELECT. Press BACK to finish.
VCR Direct View	The direct output of the VCR may be viewed here by pressing SELECT. Press BACK to finish.
Change Manager Password	The manager password may be set here. Set to "000000" if you want to allow free access. Use \leftarrow \rightarrow \uparrow \downarrow and SELECT. Press BACK to finish.

6. Specifications

6.1 Frame Stores

6.1.1 Multiplexing Update Rate (PAL)

Real time (50 fields per second) to 960 Hour Time-Lapse mode.

6.1.2 Resolution (PAL)

720 Pixels x 546 Lines x 16Million Colours (or 256 Grey levels)

6.2 Inputs/Outputs

6.2.1 Video

1V pk-pk 75Ohms or Hi-Z

6.2.2 VCR Sync

3-12V pulse or Open Collector

6.2.3 Dome

RS485 or RS422

6.2.4 Twisted Pair Telemetry

RS232, RS485, RS422 or 20mA Current Loop

6.2.5 Co-Ax Telemetry

Videoswitch 500kHz FSK telemetry, in vertical blanking period

6.2.6 Remote Control

RS232, RS485, RS422

6.2.7 Alarm Inputs

Normally Open/Normally Closed volt-free contacts

6.2.8 Alarm Relay Contacts

Change-Over contacts rated at 24Vdc, 500mA max

6.3 Connector Pin-Outs

6.3.1 Alarm Connector

This connector is used for alarm inputs (PIR detectors etc) and also for the output relay contacts. These are typically used to switch the time-lapse mode of a VCR under alarm conditions.

Mating Connector Required: Male 25-way D-Type

Pin	Function
1	Ground
2	Alarm 15
3	Alarm 17
4	Alarm 19
5	Alarm 9
6	Alarm 11
7	Alarm 13
8	Alarm 1
9	Alarm 3
10	Alarm 5
11	Alarm 7
12	Relay N/O
13	Relay N/C
14	VCR Sync
15	Alarm 16
16	Alarm 18

17	Alarm 20
18	Alarm 10
19	Alarm 12
20	Alarm 14
21	Alarm 2
22	Alarm 4
23	Alarm 6
24	Alarm 8
25	Relay Common

6.3.2 Remote Connector

This connector is used for connection to Remote Keyboards, Computers, Telemetry Receivers and Domes.

Mating Connector Required: Female 9-way D-Type

Pin	Signal Type	Description
1	GND	Signal Ground (screen)
2	RS232 Output	Dome/Receiver Output
3	RS232 Input	Remote Control (Computer) Input
4	20mA Output	Telemetry Receiver Output
5		
6	RS485 (A)	Dome/Receiver Output
7	RS485 (B)	Dome/Receiver Output
8	RS485 (A)	Remote Control (Keyboard) Input
9	RS485 (B)	Remote Control (Keyboard) Input

6.4 Power

6.4.1 DC Power

12VDC at 2Amps Maximum

6.4.2 AC Power (via main adapter provided)

230Vac 30W maximum

6.5 Physical and Environmental

6.5.1 Unit Dimensions

Case Style	Width	Depth	Height (including feet)
"Mini"	200 mm	257 mm	52 mm
19"	438 mm	284 mm	52 mm

6.5.2 Packaged Dimensions

Case Style	Width	Depth	Height (including feet)
"Mini"	395 mm	267 mm	120 mm
19"	582 mm	450 mm	120 mm

6.5.3 Weights

Case Style	Multiplexer	Power Supply	Packaged
"Mini"	1.6 Kg	1.4 Kg	3.6 Kg
19"	3.5 Kg	1.4 Kg	5.8 Kg

6.5.4 Operating Temperature

0 to 40 ° C.

6.5.5 Storage Temperature

-20 to 60 ° C

6.5.6 Humidity

5 to 95% non-condensing

6.5.7 Ventilation

Both the multiplexer and the power supply must each have adequate ventilation. Ventilation slots must not be covered, and free air flow around the units must be permitted.