



DTL-960e User Manual
Single Channel Colour Digital Video Recorder

IMPORTANT

The first few pages of these instructions contain important information on safety and product conformity. Please read, and ensure that you understand this information before continuing.

CONTENTS

Important Safeguards	4
Product Safety	4
Damage Requiring Service	5
Electromagnetic Compatibility (EMC)	5
Manufacturer's Declaration of Conformance	5
Unpacking	5
Installation Environment	5
Features, Connections and Setup	
Product Description and Features	7
Passwords	7
Front Panel Display	7
Front Panel Controls	8
Rear Panel Connections	9
User Operations	
Recording	14
Playback	15
The Search Interface	16
The Menu System	17
The Operator Menu	
Time/Date	19
Alarms	20
Timer Settings	21
Record Settings	23
Display Settings	24
Archive Setup	25
Main Menu	27
The Main Menu	
Disk Overwrite Mode	29
Disk Maintenance	30
Audio Record Setting	30
Auto Delete Mode	31
Communications (Including Ethernet Settings)	31
Multiplexer Format	31
Adjust Picture	32
Front Panel Lock	32
Factory Settings	32
Change Password	33
RS-232 Remote Protocol	34
Factory Defaults	36
Technical Specifications	37
Appendix: Archiving Devices	39

IMPORTANT SAFEGUARDS

This product is exclusively for use in CCTV applications and has no other purpose.

Read and Retain these instructions - All the safety and operating instructions should be read before the unit is operated and should be retained for future reference.

Cleaning - Unplug the unit from the supply outlet before cleaning. Use a damp cloth for cleaning. Do not use liquid or aerosol cleaners.

Attachments - Do not use attachments that have not been recommended by the product manufacturer as they may cause hazards.

Water and Moisture - Do not use this unit near water. For example, near a bathtub, wash bowl, kitchen sink, or laundry tub, in a wet basement, near a swimming pool, in an unprotected outdoor installation, or any area that is classified as a wet location.

Accessories - Do not place this unit on an unstable stand, tripod, bracket, or mount. The unit may fall, causing serious injury to a person and serious damage to the unit. Any mounting of the unit should follow the manufacturer's instructions, and should use a mounting accessory recommended by the manufacturer.

Ventilation - Openings in the enclosure are provided for ventilation to ensure reliable operation of the unit and to protect it from overheating. These openings must not be blocked or covered, and therefore this unit should not be placed in a built-in installation unless proper ventilation is provided. Do not place directly on other hot equipment, because this may increase its operating temperature.

Power Sources - This unit should be operated only from the class 2 isolated power supply provided.

Power-cord Protection - Power-supply cords should be routed so that they are not likely to be walked on or pinched by items placed upon or against them, paying particular attention to cords at plugs, and the point where they exit from the appliance.

Overloading - Do not overload outlets and extension cords as this can result in a risk of fire or electric shock.

Object and Liquid Entry - This equipment must be protected from the ingress of foreign materials. Never push objects of any kind into this unit through openings as they may touch dangerous voltage points or short-out parts that could result in a fire or electric shock. Never spill liquid of any kind on the unit.

Servicing - There are no user-serviceable parts. Do not remove the covers as this may expose you to dangerous voltages or other hazards. Refer all servicing to qualified service personnel.

Replacement Parts - When replacement parts are required, be sure the service technician has used the replacement parts specified by the manufacturer. The use of unauthorised substitute components may result in fire, electric shock or other hazards.

Safety Check - Upon completion of any service or repairs to this unit, ask the service technician to perform safety checks to determine that the unit is in proper operating condition.

Coax Grounding - If an outside cable system is connected to the unit, be sure the cable system is grounded.

Lightning - For added protection of this unit during a lightning storm, or when it is left unattended and unused for long periods, unplug it from the wall outlet and disconnect the cable system. This will prevent damage to the unit due to lightning and power-line surges.

PRODUCT SAFETY

⚠ WARNING

- Installation is only to be carried out by competent, qualified and experienced personnel in accordance with the country of installation's National Wiring Regulations.
- Your Digital Recorder contains no user-serviceable parts.
- This unit contains a lithium battery whose expected life is in excess of five years. If your Digital Recorder loses its settings each time it is switched off then the battery needs replacing. In this instance return your Digital Recorder to Baxall Limited and we will replace the battery.
- There is a danger of explosion if the lithium battery is incorrectly replaced. Replace only with the same or an equivalent type recommended by the manufacturer. Dispose of unused batteries according to the manufacturer's instructions.
- Your Digital Recorder must not be used in a medical and/or intrinsically safe application.
- Do not exceed the voltage and temperature limits given in the specification. Only operate your Digital Recorder in a clean, dry, dust-free environment.

DAMAGE REQUIRING SERVICE

Unplug the unit from the outlet and refer servicing to qualified service personnel under the following conditions:

- **When the power-supply cord or plug is damaged.**
- **If liquid has been spilled, or objects have fallen into the unit.**
- **If the unit has been exposed to rain or water.**
- **If the unit does not operate normally by following the operating instructions.**
- **If the unit has been dropped or the cabinet has been damaged.**
- **When the unit exhibits a distinct change in performance.**
- **If the unit has no power even when the power supply appears to operate correctly. If this is the case then ask a service engineer to test the internal fuse.**

ELECTROMAGNETIC COMPATIBILITY (EMC)

This is a Class A product. In a domestic environment this product may cause radio interference, in which case, the user may be required to take adequate measures.

MANUFACTURER'S DECLARATION OF CONFORMANCE

A "Declaration of Conformity" in accordance with the above EU standards has been made and is on file at Baxall Limited, Stockport, SK6 2SU, England.

The manufacturer declares that the product supplied with this document is compliant with the provisions of the EMC Directive 89/336 EEC, the Low Voltage Directive LVD 73/23 EEC, the CE Marking Directive 93/68 EEC and all associated amendments.

The product is also Y2K compliant in accordance with British Standards Institution, DISC PD2000-1.

UNPACKING

Check the package and contents for visible damage. The packaging should contain:

- The Baxall DTL-960e unit.
- Accessories PCB.
- A 12-volt power supply with power cable.
- The DTL-960e user manual.
- WaveReader software with instruction manual.

If any components are missing or damaged, contact the supplier immediately. **Do not attempt to use the unit.** If, for any reason they must be returned, the contents must be shipped in the original packaging.

INSTALLATION ENVIRONMENT

Power:

Ensure that the site's AC power is stable and within the rated voltage of the external power supply. If the site's AC power is likely to have spikes or power dips, use power line conditioning or an Uninterruptable Power Supply (UPS).

Ventilation:

Install the unit in a well-ventilated area. Take note of the locations of the cooling vents in the unit's enclosure, and ensure that they are not obstructed.

Temperature:

Observe the unit's ambient temperature specifications when choosing a location space. Extremes of heat or cold beyond the specified operating temperature limits may cause the unit to fail. Do not install the unit on top of other hot equipment.

Moisture:

Do not expose the unit to rain or moisture. Moisture can damage the internal components. Do not install this unit near sources of water.

Chassis:

You can place other equipment on top of the unit if it weighs less than 35 pounds.

FEATURES, CONNECTIONS AND SETUP

PRODUCT DESCRIPTION AND FEATURES

The DTL-960e is a Digital Video Recorder designed to be a direct replacement for a Time Lapse VCR. Digital video recording allows the user to have continuous recording on a hard disk, without the need for replacing or rewinding of videotapes. The DTL-960e provides menu based search capabilities for recorded events, as well as access to live or recorded data via the Ethernet.

Features of the DTL-960e include:

- Single channel VHS or SVHS Input/Output connection.
- Accepts single camera input or a multiplexed input from most popular multiplexers.
- Compatible with color or monochrome cameras.
- Records up to 50 pictures per second (PAL).
- Continuous recording in Disk Overwrite mode.
- LCD on front panel indicates Time, Date, Mode, and Record Speed in pps.
- Video archiving via the unit's SCSI port.
- Access to live or recorded video via the Ethernet.
- Continues recording while archiving or transmitting via the Ethernet.
- A simple on-screen menu system.
- Includes WaveReader software for viewing live or recorded images on a PC.
- Facility to program time-recorded events.

PASSWORDS

A password is provided to limit access to the **Main** menu. It is recommended that the default password be changed after installation is complete. As a security measure, store the password in the administrator's secured files or in a limited access area. For instructions on entering the **Main** menu with the password, see page 27.

A password is also provided to return the unit to the factory defaults. For instructions on returning the unit to the factory defaults, see page 32.

Password Name	Function	Changeable by user?	Password
Main Menu Password	Provides access to the Main menu for the installer.	Yes: See page 33.	3 4 7
Factory Password	Restores the unit to the factory defaults.	No	8 1 1

FRONT PANEL DISPLAY



Figure 1 - Front Panel Display

- A Time** - Displays the current time in Record and Stop mode. Displays the time the event was recorded in Play and Pause modes.
- B Date** - Displays the current date in Record and Stop mode. Displays the date the event was recorded in Play and Pause modes.
- C Mode** - Displays the mode (Record, Play, Pause, Stop, Etc.) the unit is in.
- D Record Speed** - Displays the normal record or playback speed in pps.

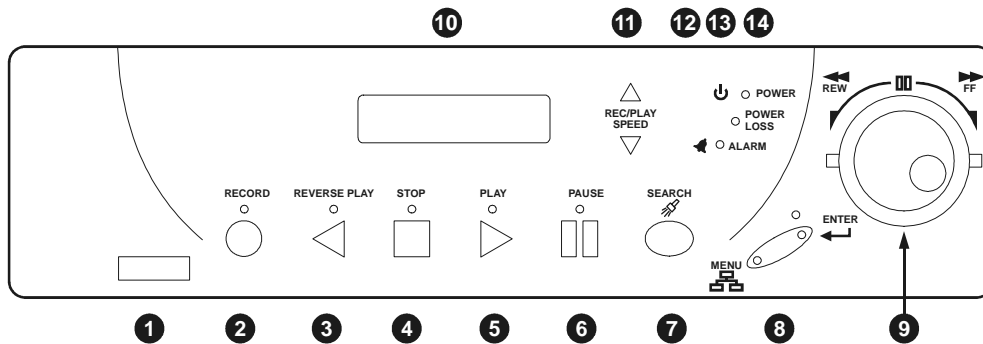

Figure 2 - Front Panel Controls

- ❶ **Infrared Port** - This feature is not yet available.
- ❷ **Record button** - Press this button to begin recording.
- ❸ **Reverse play button** - Press this button to playback video in reverse at the normal record speed.
- ❹ **Stop button** - Press this button to stop recording or playback.
- ❺ **Play Forward button** - Press this button to playback video at the normal record speed.
- ❻ **Pause button** - Press this button to pause playback.
- ❼ **Search button** - Press this button to enter the **Search Filters** menu.
- ❽ **Combination Menu and Enter button** - Press the lower half of the button (the **Menu** button) to enter the menu system. This half of the button is also used to exit without saving while in the menu system. Press the upper half of the button (the **Enter** button) to make or confirm a selection in the menu system.
- ❾ **Jog / Shuttle** - The **Jog** (the inner of the two dials) is used for single frame advance while in Pause mode, and is also used to change the value of a parameter while in the menu system. The **Shuttle** (the outer of the two dials) is used to fast forward and rewind while in the Play mode, and is also used to navigate while in the menu system.
- ❿ **LCD** - Displays the time, date, mode, and record or playback speed in pictures per second (pps).
- ⓫ **Increase and Decrease Record Speed buttons** - Press these buttons to increase or decrease the record or playback speed.
- ⓬ **Alarm Indicator** - Indicates an alarm condition when the LED is lit.
- ⓭ **Power Loss Indicator** - Indicates power loss when LED is lit.
- ⓮ **Power On Indicator** - Indicates power is on when LED is lit.

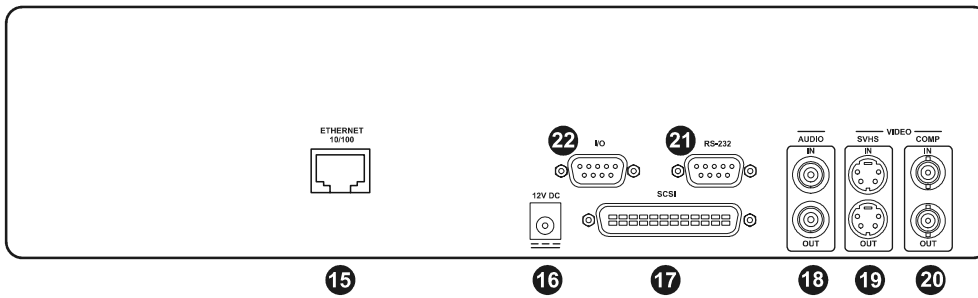

Figure 3 - Rear Panel Connections

15 Ethernet Port

The Ethernet Port is used to view live or recorded images on a PC via the Ethernet.

The cable connection configuration depends on your network configuration:

- For a DTL-960e that connects directly to a Hub, use a Straight Through connection.
- For a DTL-960e that connects directly to a PC, use a Cross Over connection.

Consult with your Network Administrator for the specific type of configuration. See page 31 for information about configuring the ethernet settings in the menu system.

Wire Type	Cat 5
Connector Type	RJ-45
Max Cable Length	100 feet / 30.5 meters
Minimum Cable Length	6 feet / 1.8 meters
Hub Wiring Configuration	Straight Through
PC Wiring Configuration	Cross Over

Pin	Use
1	TX+
2	TX-
3	RX+
4	Not connected
5	Not connected
6	RX-
7	Not connected
8	Not connected

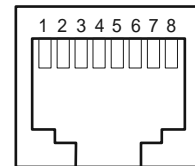

Figure 4 - RJ-45 Pin Configuration For Ethernet Port

16 Power Connector

The unit is furnished with a 12V DC power supply.

Do not use any other power supply with the unit. The manufacturer accepts no responsibility for damage caused by the use of any other power supply.

Power Supply Input:	
Voltage	120 to 240 Volt AC
Tolerance	±10%
Frequency	50 to 60 Hz
Power Supply Output:	
Voltage	12 Volt DC
Power	62 Watts
Connector	2.1mm barrel, Centre Positive

17 SCSI Port

The unit is equipped with a SCSI port for connecting external archive devices. The unit only supports a single SCSI device. The SCSI ID must be set to 0 and the SCSI bus must be terminated, otherwise the system will not operate correctly.

Connector	50 Pin, High Density SCSI-2
Gender (on unit)	Female
Compatible devices	DAT, AIT, CD-R, CD-RW
Autoloader Support?	Yes
SCSI ID	0

18 Audio In/Out

The unit is equipped with a mono audio input and output for the recording and playback of sound.

19, 20 Video Input and Output

The unit is equipped with both SVHS (Y/C separated video signal) and Composite inputs and outputs. The video inputs are auto-terminating.

The SVHS input is Active Looping, and will only loop while the unit is on.

△ SVHS Input	4-pin Mini-DIN connector
SVHS Output	4-pin Mini-DIN connector
SVHS Looping	Only while unit is On
△ Composite Input	75 Ohm BNC connector
Composite Output	75 Ohm BNC connector
Composite Looping	Yes, while unit is On or Off

△ CAUTION

Do not connect both video inputs at the same time.

21 RS-232 Serial Port

The RS-232 Serial Port is provided for software upgrades, and for external control of the unit. Use a Null Modem cable when connecting to a PC.

Connector Type	DB9
Gender (on unit)	Male
Cable Required (Connected to PC)	Null Modem
Cable Required (Connected to Multiplexer)	Variable, depending on pin-out configuration of MUX

When connecting to a multiplexer, it may be necessary to construct a cable using the pin-out documentation of the MUX as a guide. See the pin-out configuration for the DTL-960e below.

Pin	Use
1	DCD
2	RX
3	TX
4	Not connected
5	Ground
6	Not connected
7	RTS
8	CTS
9	Not connected

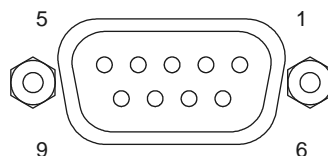

Figure 5 - DB-9 Pin Configuration For RS-232 Serial Port

22 Accessories I/O Port

The rear panel of the unit is equipped with an Accessories Port (DB-9 style connector). It is used for connecting peripheral devices such as alarm devices, alarm relays, or the VEXT connection.

Wire all accessories to the Accessories PCB (supplied with the unit), and connect it to the Accessories Port.

△ CAUTION

Do not attempt to wire accessories directly to the DB-9 connector.

Pin	Use
1	Alarm In
2	Alarm Out
3	Record Start In
4	Alarm Record Reset
5	VEXT Pulse Out
6	Error Out
7	Ground
8	Videoloss Out
9	Disk End Out
10	Ground

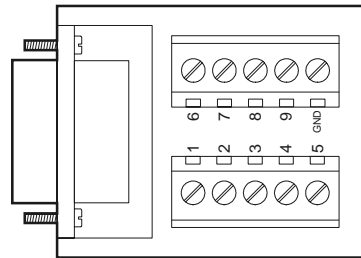

Figure 6 - Pin Configuration for Accessories PCB

Alarm In

An alarm condition can be activated by an Active Low TTL input or by relay contact devices such as pressure pads, passive infrareds, door switches, or other similar devices.

Input: Active Low TTL with pull-ups or Normally Open relay
High: 5V (12V max.)
Low: Ground

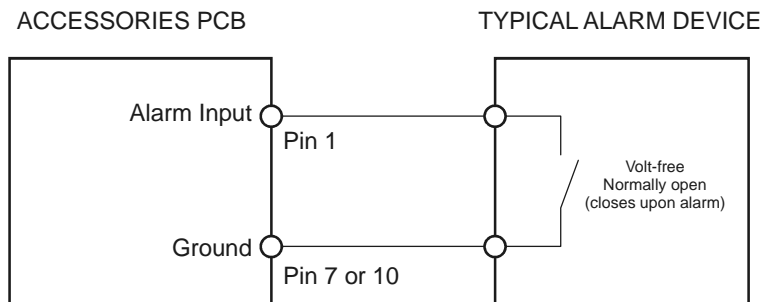
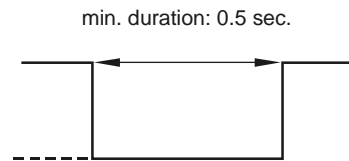
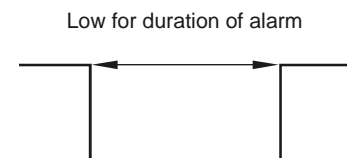

Figure 7 - A Normally Open Relay Alarm Condition

Alarm Out

The Alarm output is activated when a teletext alarm is read, or while the Alarm Input is active. The Alarm output is only active for the duration of the alarm event.

Input: Active Low
High: 12V
Low: Ground
Current out: 50mA max. (short circuit protected)



REAR PANEL CONNECTIONS

Record Start In

Record Start In will place the unit in Record mode when activated. Compatible with the Disk End Out signal from a second unit.

Input: Active Low TTL with pull-ups or Normally Open relay
High: 5V (12V max.)
Low: Ground

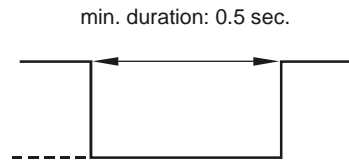

Alarm Record Reset

This feature is for future development, and has not yet been implemented.

VEXT Pulse Out

The Video External Pulse connection (VEXT) simplifies multiplexer operation by automatically synchronizing the multiplexer and the DTL-960e. The DTL-960e sends a VEXT pulse to the multiplexer indicating that it is ready to record the next image. The multiplexer responds by sending the next image to the Video Input on the DTL-960e.

The VEXT connection is especially beneficial for units configured with dual record speeds (Normal and Alarm).

Output: Active Low
High: 5V
Low: Ground (0.8V max.)
Current out: 50mA max. (short circuit protected)



Use of the VEXT connection is highly recommended when connecting the unit to a multiplexer.

Error Out

This feature is for future development, and has not yet been implemented.

Videoloss Out

The Videoloss Out signal is activated when the unit experiences videoloss on the selected video input (Composite or SVHS).

In the event of videoloss, **VIDEOLOSS** will be indicated near the upper left hand corner of the primary monitor.

Output: Open Collector
High: Transistor Off
Low: Transistor On
Active when On
Current out: 10mA max.

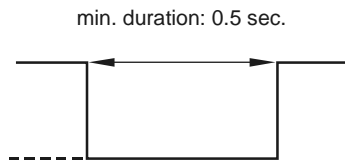

Disk End Out

The Disk End Out is activated when there is 5 minutes of recording space left on the hard disk.

Output: Open Collector
High: Transistor Off
Low: Transistor On
Active when On
Current out: 10mA max.

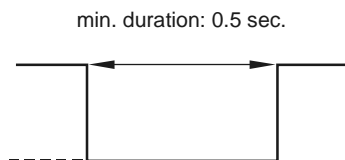

USER OPERATIONS

RECORDING

To begin recording, press the **Record** button. **RECORD** will be indicated for three seconds, near the upper left hand corner of the primary monitor. The unit always starts recording at the end of the previously recorded data.



Recording will continue until:

- Another mode is selected (Play mode, Stop mode, Fast Forward, Etc.).
- The disk is full (in No Overwrite and Overwrite Once modes). See page 29 for details regarding Disk Overwrite modes.
- Videoloss is detected. In the event of videoloss, **VIDEOLOSS** will be indicated near the upper left hand corner of the primary monitor.

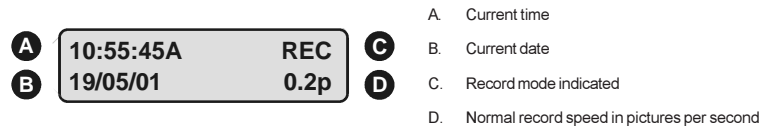

Figure 8 - LCD Display in Record mode

Normal Record Speed

The unit records at the normal record speed until an alarm condition is detected. The normal record speed is indicated on the LCD, and can be altered using the **Up/Down Record Speed** buttons, or in the menu system. The normal record speed can be altered while the unit is recording.

For information about altering the normal record speed using the menu system, see page 23.



Alarm Record Speed

When an alarm condition is detected, the unit automatically switches to the alarm record speed. The alarm condition is indicated in several ways:

- With the word **ALARM**, displayed on the primary monitor, near the upper left hand corner of the screen.
- With the LED Alarm Indicator on the front panel of the unit.
- With the internal buzzer (if activated in the menu system). For information about activating the internal buzzer during alarms, see page 20.
- By an external device, connected to the alarm output of the unit (if the unit is installed that way).

The alarm record speed cannot be changed using the **Up/Down Record Speed** buttons on the front panel. This must be carried out using the menu system. For information about altering the alarm record speed and incident recording in general, see page 23.

During an alarm condition, the front panel LCD does not change and continues to display the normal record speed, although the unit is recording at alarm record speed. The unit returns to the normal record speed when the alarm condition ends.

Note: If a teletext alarm is received from the multiplexer, the DTL-960e must be in Record mode in order to automatically switch to alarm record speed. See page 20 for more information on the teletext alarm.

Disk Full Notification

When the disk is full, a message will appear on the primary monitor to indicate that the unit has stopped recording, because there is no space to do so.

In No Overwrite mode: The user must acknowledge the on-screen message by pressing the **Enter** button. The unit will not record over previously recorded data. To continue recording, the data must be erased (or deleted) using the **Disk Maintenance** feature. For more details on this feature, see page 30.

In Overwrite Once mode: The user must acknowledge the on-screen message by pressing the **Enter** button. The unit will continue recording again when the user presses the **Record** button.

When data is played back on the DTL-960e, the details on the front panel LCD change accordingly:

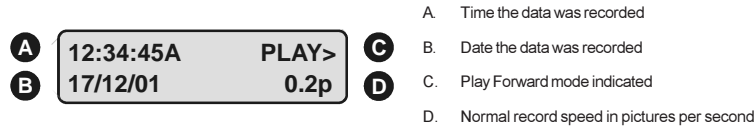

Figure 9 - LCD Display in Playback mode

Play Forward

To begin normal playback, press the **Play Forward** button. The unit will begin playing back data from the beginning of the last recording session. Playback is indicated:

- As **PLAY** near the upper left hand corner of the primary monitor, for three seconds.
- As **PLAY>** on the LCD.



Reverse Play

To begin reverse playback, press the **Reverse play** button. The unit will begin playing back data from the beginning of the last recording session. Reverse playback is indicated:

- As **REVERSE PLAY** near the upper left hand corner of the primary monitor, for three seconds.
- As **PLAY<** on the LCD.



If there is only one recording session on the hard disk, the unit will indicate **START OF DATA** on the primary monitor.

Playback Speed

When playback commences, the unit will play the data at the rate it was recorded. However, the user can alter the playback speed using the **Up/Down Record Speed** buttons.

Altering the playback speed overrides any change in playback speed that would occur due to an alarm condition in the playback. To clear the override, press the **Stop** button, then press the **Play** button to resume playback at the speed the data was recorded.

The playback speed is indicated on the LCD in Pictures Per Second.



Fast Forward & Rewind

During playback the data can be viewed at a higher than normal rate by rotating the **Shuttle** clockwise. The data can also be viewed at a higher than normal rate in reverse by rotating the **Shuttle** counter-clockwise. Increasing the amount of rotation increases the rate of playback. Fast Forward & Rewind are indicated:

- As **FAST FORWARD** or **REWIND** near the upper left hand corner of the primary monitor, for three seconds.
- As **FFWD** or **REW** on the LCD.



Pause

During playback, press the **Pause** button to pause playback, and display a single frame on-screen. Pause is indicated:

- As **PAUSE** near the upper left hand corner of the primary monitor, for three seconds.
- As **PAUSE** on the LCD.

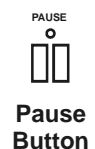

Single Frame Advance & Single Frame Rewind

During Pause mode, rotate the **Jog** dial to view the frame directly before or after the frame displayed on-screen.

Start of Data & End of Data

If the start or end of data is reached during playback, **START OF DATA** or **END OF DATA** is indicated near the upper left hand corner of the primary monitor.

THE SEARCH INTERFACE

The Search Interface feature allows the user to search the hard disk for recorded events, such as an alarm condition, or a previous recording session. For example, each time Record mode is activated, it is considered a separate recording session.

To enter the **Search Filters** menu, press the **Search** button. The **Search Filters** menu is displayed on the primary monitor:



Search Button

Search Filters					
DATE:	Start	[]	Stop	[]	
	12/25/00		01/01/01		
	(MM/DD/YY)		(MM/DD/YY)		
TIME:	Start	[]	Stop	[]	
	11:11:21		12:34:34		
CAMERA:	1	2	3	4	5
	[]	[]	[]	[]	[]
ALARM:	[]				
	[CANCEL]		[START SEARCH]		

Note: The **Search Filters** menu can also be accessed via the Selective Archive and Restore from Archive features in the menu system. See page 25 for more details on these features.

Selecting a Start and Stop Date / Start and Stop Time:

1. Using the **Shuttle** to navigate, highlight the **DATE** parameter, then press the **Enter** button. The unit will enter Edit mode.
2. Use the **Jog** to change the start and stop date values. Use the **Shuttle** to navigate among the different parameters.
3. To activate the start or stop date parameter, use the **Jog** to place an **[X]** in the check box.
4. Press the **Enter** button at any time to exit Edit mode.
5. To select a Start and Stop Time, repeat steps 1 to 4 with the **TIME** parameter.

Selecting Cameras and Recorded Alarms:

1. Using the **Shuttle** to navigate, highlight the **CAMERA** parameter, then press the **Enter** button. The unit will enter Edit mode.
2. Use the **Shuttle** to navigate among the different cameras.
3. Use the **Jog** to select a camera (or cameras) that is to be searched for alarms by placing an **[X]** in the check box.
4. Press the **Enter** button to exit Edit mode.
5. Using the **Shuttle** to navigate, highlight the **ALARM** parameter, then press the **Enter** button. The unit re-enters Edit mode.
6. Use the **Jog** to activate the alarms search, by placing an **[X]** in the check box.
7. Press the **Enter** button at any time to exit Edit mode.

Note: It is possible to search for all recorded events. To do this, ensure that all the check boxes are blank [].

Starting the Search:

Using the **Shuttle** to navigate, highlight **[START SEARCH]** and then press the **Enter** button. The search results will appear. To select a recorded event from the search results, use the **Shuttle** to highlight the event and then press the **Enter** button.

Press the **Menu** button to exit the **Search Results** menu.

The DTL-960e can be configured using a menu based system that can be viewed when the unit is connected to a monitor. The menu system contains two pull-down menus and a number of pop-up menus, and is accessed by pressing the **Menu** button:

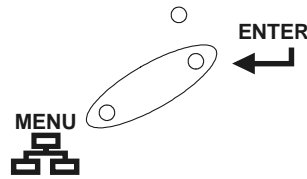

Pull-down menus

The pull-down menus are the top-level menus. By making a selection in a pull-down menu, the appropriate sub-menu will open (typically a pop-up menu). Changes to the unit's parameters are usually made in the pop-up menus, not the pull-down menus.

There are two pull-down menus available:

Time/Date Alarms Timer Settings
Record Settings Display Settings Archive Setup
Main Menu

The Operator menu

The **Operator** menu provides access to all of the operator programmable options.

It also provides the entry point to the second pull-down menu, via the **Main Menu** option.

For details on this menu, see the section **The Operator Menu** that begins on the next page.

Disk Overwrite Mode Disk Maintenance Audio Record Setting Auto Delete Mode Communications
Multiplexer Format
Adjust Picture Front Panel Lock Factory Settings Change Password

The Main menu

For security reasons, a password is provided to limit access to the **Main** menu. This password must be entered when the **Main Menu** option is selected from the **Operator** menu.

The **Main** menu provides access to all of the installer programmable options.

For details on this menu, see the section **The Main Menu** that begins on page 28.

Pop-up menus

Pop-up menus usually have a parameter (or several parameters) from which the user can make a selection or change the value of the parameter.

There are two types of pop-up menus:

Adjust Brightness
050
[CANCEL] [OK]

The first type of pop-up menu has **[OK]** or **[CANCEL]** options at the bottom.

Use the **Shuttle** to select the parameter that you want to change, and then use the **Jog** to change the value. To save the changes and exit the menu, use the **Jog** to select **[OK]**, then press the **Enter** button. To exit the menu without making changes, use the **Jog** to select **[CANCEL]**, then press the **Enter** button.

The **Menu** button can also be used to exit the pop-up menu at any time.

Archive Overwrite Mode
Select Mode
Continuous Overwrite

The second type of pop-up menu is different in that there are no **[OK]** or **[CANCEL]** options at the bottom.

Use the **Jog** to change the value of the parameter. Press the **Enter** button to confirm the selection and exit the menu, or press the **Menu** button to exit the menu without making changes.

THE OPERATOR MENU

This section covers the Operator menu system

Time/Date Alarms Timer Settings
Record Settings Display Settings Archive Setup
Main Menu

```
Set Time Format
Set Date Format
Set Time
Set Date
```

When the **Time/Date** menu item is selected, a sub-menu is displayed. From this sub-menu, you can specify:

- The time format: 12 or 24 hours.
- The date format: MM/DD/YY, DD/MM/YY, or YY/MM/DD.
- The time.
- The date.

```
Time Format Setup

Select Format
12 HOUR
```

Set Time Format

This menu option displays the **Time Format Setup** dialog. In this dialog, use the **Jog** to select the desired time format. The options available are:

- **12 HOUR**
- **24 HOUR**

Press the **Enter** button to confirm the selection and exit the menu.

```
Date Format Setup

Select Format
DD/MM/YY
```

Set Date Format

This menu option displays the **Date Format Setup** dialog. In this dialog, use the **Jog** to select the desired date format. The options available are:

- **DD/MM/YY**
- **MM/DD/YY**
- **YY/MM/DD**

Press the **Enter** button to confirm the selection and exit the menu, or press the **Menu** button to exit the menu without making changes.

```
Time Setup

HH MM SS
10 13 01

[CANCEL] [OK]
```

Time Setup

This menu option displays the **Time Setup** dialog, where you can set the time. To do this:

1. With **HH MM SS** highlighted, press the **Enter** button. The highlighting will move to the row of numbers.
2. Enter the time in Hours, Minutes, and Seconds. Use the **Jog** to change the values. Use the **Shuttle** to navigate among the three fields.
3. Press the **Enter** button to confirm the selection.
4. To save the changes and exit the menu, use the **Jog** to select **[OK]**, then press the **Enter** button. If you want to exit the menu without making changes, use the **Jog** to select **[CANCEL]**, then press the **Enter** button.

```
Date Setup

MM DD YY Day
01 01 98 1

[CANCEL] [OK]
```

Date Setup

This menu option displays the **Date Setup** dialog, where you can set the date. To do this:

1. With **MM DD YY DAY** highlighted, press the **Enter** button. The highlighting will move to the row of numbers.
2. Enter the date in Months, Days, Years. The day of the week will update automatically. Use the **Jog** to change the values. Use the **Shuttle** to navigate among the three fields.
3. Press the **Enter** button to confirm the selection.
4. To save the changes and exit the menu, use the **Jog** to select **[OK]**, then press the **Enter** button. If you want to exit the menu without making changes, use the **Jog** to select **[CANCEL]**, then press the **Enter** button.

Alarms Menu	
Hardwire Alarm :	Enable
Teletext Alarm :	Disable
Alarm Buzzer :	Enable
	[CANCEL] [OK]

The **Alarms** menu is used to specify:

- Whether an alarm condition will be activated when the unit detects a signal on the Alarm In connection.
- Whether a teletext alarm signal (generated by a multiplexer or other device) will cause the unit to activate an alarm condition.
- Whether the internal buzzer is activated during an alarm condition.

To configure these alarm settings:

1. Use the **Shuttle** to navigate among the fields.
2. Use the **Jog** to change the values of the highlighted fields.
3. To save the changes and exit the menu, use the **Jog** to select **[OK]**, then press the **Enter** button. To exit the menu without making changes, use the **Jog** to select **[CANCEL]**, then press the **Enter** button.

Connecting to Dedicated Micros (DM)

A feature unique to the DTL-960e is its ability to detect alarms via teletext provided within the video signal. Standard Time Lapse VCRs can only detect an alarm if the alarm output signal of the multiplexer is wired directly to the alarm input of the VCR.

This alarm detecting feature of the DTL-960e is compatible with the following styles of multiplexers:

- ZMX
- Philips
- Robot

To use this function on a Dedicated Micros multiplexers, you need to:

1. Connect the alarm output of the multiplexer to the alarm input of the DTL-960e (as you would do when connecting the alarm input on standard time-lapse VCR).
2. In the Alarms menu, set the **Hardwire Alarm** option to **Enable**.
3. Set the **Teletext Alarm** option to **Disable**.

DATE	START	STOP	SPD(pps)	QUALITY	ON/OFF
31	16:45	17:05	20	High	On
Sat	07:55	08:10	10	Med	Off
Mon-Fri	09:56	11:05	60	Low	On
Sat-Sun	14:23	14:50	60	High	On
Mon-Sun	02:23	03:34	20	Med	Off
--	--:--	--:--	--	--	--
[OK]					
EDIT Mode		Hit "ENTER" to Toggle EDIT Mode			

This menu item allows the user to program a timed-recorded event. Use this menu to specify:

- The date, or days on which the recording will occur.
- The start and stop time.
- The record speed.
- The record quality.
- Whether the event is enabled.

Creating a Timed Recording

1. Using the **Jog/Shuttle** to navigate, highlight the **DATE** parameter of the last line item (indicated with double dash marks).
2. Press the **Enter** button to enter the Edit mode. **EDIT MODE** will appear on-screen, in the lower left-hand corner of the Timer Settings menu. The user may press the **Enter** button to exit Edit mode at any time.
3. Use the **Jog** to change the values of the **DATE** setting. The values available are:
 - **Date (Day of the Month)** - 1 through 31
 - **Day of the Week** - Monday through Sunday
 - **Range of Days** - All Weekdays (Monday-Friday), All Weekend Days (Saturday-Sunday), Monday-Sunday (Everyday)
4. Use the **Shuttle** to navigate to the **START** setting.
5. Use the **Jog/Shuttle** to enter the time the recording will begin. The hours and minutes are edited separately. The start and stop times are always configured in a 24-hour clock.
6. Use the **Shuttle** to navigate to the **STOP** setting.
7. Use the **Jog/Shuttle** to enter the time the recording will end. Entering a time before the start time will cause the unit to record until the indicated stop time on the next day.
8. Use the **Shuttle** to navigate to the **SPD** setting.
9. Use the **Jog** to enter the record speed in pictures per second. The **PAL Record Speeds** available are 50, 25, 17, 10, 5, 3, 2, 1, 0.5, 0.2, 0.1 and 0.0 (where 0.0 is alarm event recording).
10. Use the **Shuttle** to navigate to the **QUALITY** setting.
11. Use the **Jog** to enter the record quality (Low, Medium, or High). Higher record quality settings use more disk space.
12. Use the **Shuttle** to navigate to the **ON/OFF** setting.
13. Use the **Jog** to Activate, Deactivate or Delete the recording.
14. When finished, press the **Enter** button to exit the Edit mode. Use the **Jog / Shuttle** to navigate to **[OK]**, then press the **Enter** button to complete the selection.

Editing a Timed Recording

1. Using the **Jog/Shuttle** to navigate, highlight the event parameter you wish to edit.
2. Press the **Enter** button to enter the Edit mode. **EDIT MODE** will appear on-screen, in the lower left-hand corner of the pop-up menu.
3. Use the **Jog** to change the values. Use the **Shuttle** to navigate among parameters in the same row.
4. When finished, press the **Enter** button to exit the Edit mode. Use the **Jog / Shuttle** to navigate to **[OK]**, then press the **Enter** button to complete the selection.

Deleting a Timed Recording

1. Using the **Jog/Shuttle** to navigate, highlight the **ON/OFF** parameter of the event you wish to delete.
2. Press the **Enter** button to enter the Edit mode.
3. Use the **Jog** to select **DEL** from the menu.
4. Press the **Enter** button to confirm the selection and exit the Edit mode.
5. Use the **Jog/Shuttle** to navigate to **[OK]**, then press the **Enter** button to remove the selection and exit the menu.

RECORD SETTINGS

Record Input
Normal Record Speed
Alarm Record Speed
Video Quality

When the **Record Settings** menu item is selected, a sub-menu is displayed. From this sub-menu, you can specify:

- Which video input on the rear panel is activated.
- The record speed during normal recording.
- The record speed when the unit detects an alarm condition.
- The recorded picture quality.

Composite Video
SVHS Video

Record Input

To select a video input, use the **Jog** to select either:

- **Composite Video** - A video input with BNC style connector.
- **SVHS Video** - A Y/C video input with 4-pin mini-DIN style connector.

To confirm the selection and exit the menu, press the **Enter** button. To exit the menu without making changes, press the **Menu** button.

△ CAUTION

Do not connect both video inputs at the same time.

Normal Record Speed
Pictures Per Second
5

Normal Record Speed

Use the **Jog** to select the desired Normal Record Speed. The options available are 50, 25, 17, 10, 5, 3, 2, 1, 0.5, 0.2, 0.1 and 0.0 pictures per second.

When the normal record speed is set to 0.0, the unit will only record while an alarm is active.

To confirm the selection and exit the menu, press the **Enter** button. To exit the menu without making changes, press the **Menu** button.

Alarm Record Speed
Pictures Per Second
50

Alarm Record Speed

Use the **Jog** to select the desired Alarm Record Speed. The options available are 50, 25, 17, 10, 5, 3, 2, 1, 0.5, 0.2 and 0.1 pictures per second.

To confirm the selection and exit the menu, press the **Enter** button. To exit the menu without making changes, press the **Menu** button.

Record Quality
Select Quality
High

Video Quality

Use the **Jog** to select the desired Record Quality. The available options are **High**, **Med** or **Low**. Higher record quality's use lower compression, requiring more disk space.

To confirm the selection and exit the menu, press the **Enter** button. To exit the menu without making changes, press the **Menu** button.

DISPLAY SETTINGS

Current Time / Date Record Capacity Archive Status Last Alarm
Playback Time / Date

When the **Display Settings** menu item is selected, a sub-menu is displayed. From this sub-menu, you can specify what status information will be displayed on the primary monitor. Select **ON** or **OFF**, for the following items:

- The current time and date.
- The remaining amount of time before the hard disk runs out of record space.
- The archive status.
- The time and date of the last alarm.
- During playback, the time and date the recording was made.

Current Time / Date

Select this menu item to set whether the current time and date are to be displayed near the upper right hand corner of the primary monitor.

Use the **Jog** to select **On** or **Off**. To confirm the selection and exit the menu, press the **Enter** button. To exit the menu without making changes, press the **Menu** button.

Record Capacity

Select this menu item to set whether the amount of time remaining before the hard disk runs out of record space is to be displayed near the upper left hand corner of the primary monitor. If it is displayed, the unit shows the record capacity with two measures of time, and switches automatically depending on the amount of time remaining:

- Days and Hours
- Hours and Minutes
- Minutes and Seconds

Use the **Jog** to select **On** or **Off**. To confirm the selection and exit the menu, press the **Enter** button. To exit the menu without making changes, press the **Menu** button.

Archive Status

Select this menu item to set whether the archive status is to be displayed near the upper center of the screen on the primary monitor. If it is displayed, the unit will display either:

- **ARCHIVE NOT CONNECTED**
- **ARCHIVE READY**
- **ARCHIVE NOT READY**

Use the **Jog** to select **On** or **Off**. To confirm the selection and exit the menu, press the **Enter** button. To exit the menu without making changes, press the **Menu** button.

Last Alarm

Select this menu item to set whether the time and date of the last alarm are to be displayed near the upper right hand corner of the primary monitor. If it is displayed, the unit will display **NONE** if there is no previous record of an alarm.

Use the **Jog** to select **On** or **Off**. To confirm the selection and exit the menu, press the **Enter** button. To exit the menu without making changes, press the **Menu** button.

Playback Time / Date

Select this menu item to set whether the time and date the recording was made (during playback) are to be displayed near the upper right hand corner of the screen.

Use the **Jog** to select **On** or **Off**. To confirm the selection and exit the menu, press the **Enter** button. To exit the menu without making changes, press the **Menu** button.

Use this section in conjunction with the Archiving Devices Appendix found at the back of this manual.

Selective archive Restore from archive Background archive
Archive Overwrite Mode
Erase Archive Medium

When the **Archive Setup** menu item is selected, a sub-menu is displayed. Use this sub-menu to:

- Select data to be archived and begin archiving process.
- Restore data from an archive device.
- Enable background archiving.
- Specify how the unit will handle overwrite issues when the archive medium becomes full.
- Erase the archived data.

Selective archive

The Selective Archive feature allows the user to archive recorded data from the hard disk onto a CD, for later viewing on a PC. Recorded data can also be archived to a DAT or an AIT.

When this menu item is selected, the **Search Filters** menu is displayed. This allows the user to search the hard disk for recorded events, such as an alarm condition, or a previous recording session. For details on completing the fields in the **Search Filters** menu, see the section **The Search Interface** on page 16.

When a search has been completed, the results are displayed in the **Archive Search Results** dialog:

Archive Search Results			
	Start Date	Start Time	Size(MB)
000	11/28/2000	17:52:14	26842 []
001	11/29/2000	09:35:20	2062 []
002	11/29/2000	10:00:04	278 [x]
003	11/29/2000	10:03:25	66 [x]
			Selected [383] (MB)
			Available Target on Medium [652] (MB)
"ENTER" to play		"SEARCH" to archive	

Note: If no archiving device is connected, the **Archive Search Results** dialog will display a no data available message.

It is now possible to select and archive recorded events:

1. Using the **Jog** to navigate, highlight the recorded event that is to be archived.
2. Use the **Shuttle** to select the recorded event by placing an **[X]** in the check box.
3. Repeat steps 1 and 2 to select all the recorded events that are to be archived.
4. Press the **Search** button. The Archiving progress bar will appear. Press the **Enter** button to cancel archiving at any time.

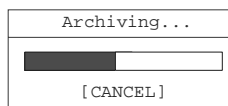

5. When the unit is finished archiving, a completion message will appear. Press the **Enter** button to acknowledge the message and complete the archiving process.

Restore from archive

The DTL-960e supports data restoration to the hard disk from an archive device.

To do this, select the **Restore From Archive** menu item. The **Search Filters** menu is displayed, and from this menu the user can search the archive device for the archive that is to be restored. For details on completing the fields in the **Search Filters** menu, see the section **The Search Interface** on page 16.

When a search has been completed, the results are displayed **Restore Archive Search Results** dialog:

Restore Search Results			
	Start Date	Start Time	Size(MB)
000	11/28/2000	17:52:14	26842 []
001	11/29/2000	09:35:20	2062 []
002	11/29/2000	10:00:04	278 [x]
003	11/29/2000	10:03:25	66 [x]
			Selected [383] (MB)
Available Target on Medium			[29216] (MB)
"ENTER" to play		"SEARCH" to restore	

It is now possible to select and restore archived events:

1. Using the **Jog** to navigate, highlight the archived event that is to be restored.
2. Use the **Shuttle** to select the archived event by placing an **[X]** in the check box.
3. Repeat steps 1 and 2 to select all the archived events that are to be restored.
4. Press the **Search** button. The Restoring progress bar will appear. Press the **Enter** button to cancel the restoring process at any time.

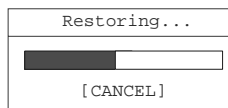

5. When the event has been restored, a completion message will appear. Press the **Enter** button to acknowledge the message and complete the process.



Background archive

With the Background Archiving feature turned on, the unit archives recorded data automatically. Data is recorded to both the hard disk and the archiving device simultaneously.

Use the Jog to select **ON** of **OFF**. To confirm the selection and exit the menu, press the **Enter** button. To exit the menu without making changes, press the **Menu** button.

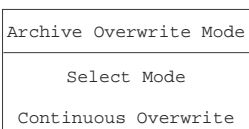

Archive Overwrite Mode

Specify how the unit will handle overwrite issues when the archive medium becomes full. This feature is only available when using an auto loader.

The unit handles archive overwrite issues in three ways:

- No Overwrite
- Overwrite Once
- Continuous Overwrite

Use the **Jog** to make the selection. To confirm the selection and exit the menu, press the **Enter** button. To exit the menu without making changes, press the **Menu** button.

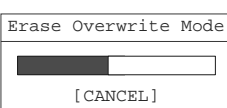

Erase Archive Medium

To erase the archived data, move the cursor to this menu item and press the **Enter** button. The Erasing Media progress bar will appear. Press the **Enter** button to cancel archiving at any time. When the unit is finished erasing the data, a message box will appear confirming that the process has finished. Press the **Enter** button to acknowledge the message and complete the deleting process.

This feature is not available when archiving to a CD-R device.

MAIN MENU

Password Box
Please Enter The Password! - - -

For security reasons, a password is provided to limit access to the **Main** menu. By selecting this menu item, a password entry box is displayed and the Main Menu Password must be completed correctly in order to gain access.

Use the **Jog** to select a number, then use the **Enter** button to complete the selection, and move to the next number. Pressing the **Enter** button on the last number will complete the password selection and the unit will display the **Main** menu.

See page 7 for more details on passwords.

THE MAIN MENU

This section covers the Main menu system

Disk Overwrite Mode Disk Maintenance Audio Record Setting Auto Delete Mode Communications
Multiplexer Format
Adjust Picture Front Panel Lock Factory Settings Change Password

DISK OVERWRITE MODE

The **Disk Overwrite Mode** menu item is used to specify how the unit will handle disk overwrite issues once the hard disk becomes full. The DTL-960e can handle disk overwrite issues in three ways:

Disk Overwrite Mode
Select Mode
Continuous Overwrite

- No Overwrite.
- Overwrite Once.
- Continuous Overwrite.

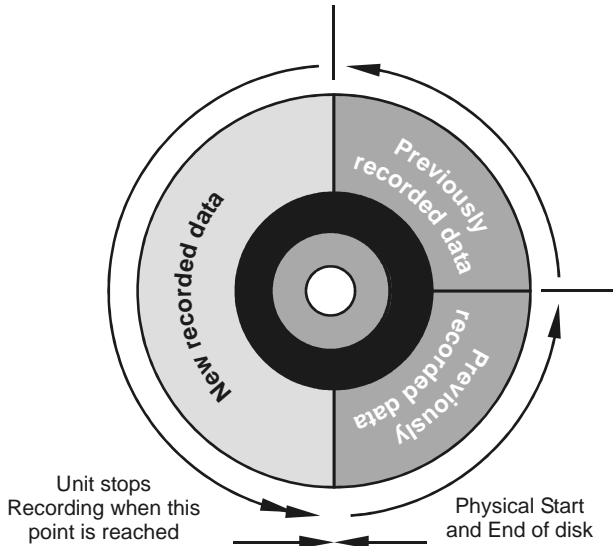

Figure 10 - No Overwrite Mode

No Overwrite

When No Overwrite mode is selected, the DTL-960e will function as follows:

- Recording always starts at end of last recording.
- Recording stops when end of disk is reached (when disk is full).
- When the end of the disk is reached, the unit displays an on-screen message indicating that the disk is full, and the unit has stopped recording. User must acknowledge the on-screen message by pressing the **Enter** button.
- The DTL-960e will not record over previously recorded data. To continue recording, the data must be erased (or deleted). See page 30 for details on how to do this.

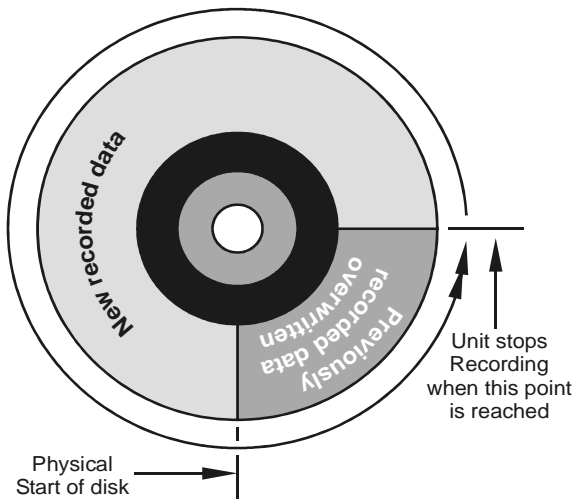

Figure 11 - Overwrite Once Mode

Overwrite Once

When Overwrite Once mode is selected, the DTL-960e will function as follows:

- Recording always starts at end of last recording.
- The unit overwrites all previously recorded data.
- Recording stops before the unit overwrites any of the new recorded data (data from the current record session).
- When the end of the disk is reached, the unit displays an on-screen message indicating that the disk is full, and the unit has stopped recording. User must acknowledge the on-screen message by pressing the **Enter** button.
- The unit will continue recording again when the user presses the **Record** button.

DISK OVERWRITE MODE

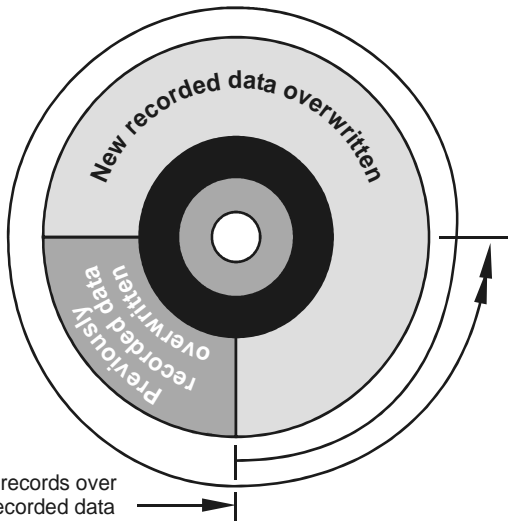

Figure 12 - Continuous Overwrite Mode

Continuous Overwrite Mode

When Continuous Overwrite mode is selected, the DTL-960e will function as follows:

- Recording always starts at end of last recording.
- The unit overwrites all previously recorded data.
- The unit overwrites new recorded data (data from the current record session).
- Unit never stops recording.
- Record Capacity display will not count down.

DISK MAINTENANCE

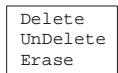

From the **Disk Maintenance** sub-menu, the user can have previously recorded information:

- Deleted (with the possibility of restoring it).
- Undeleted (restored if it has not yet been overwritten).
- Erased (removed with no possibility of restoring it).

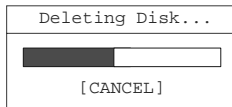

Delete

To begin deleting the disk, use the **Jog** to select **Delete**, then press the **Enter** button. The **Deleting Disk** dialog will appear and the unit will begin deleting the oldest recorded information immediately. To stop the delete process, select **[CANCEL]** by pressing the **Enter** button.

Data that was deleted before **[CANCEL]** was selected will remain deleted unless **UNDELETE DISK** is selected.

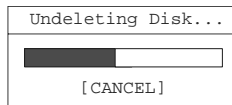

UnDelete

To restore information that was previously deleted, use the **Jog** to select **UnDelete**, then press the **Enter** button.

To stop the restore process, select **[CANCEL]** by pressing the **Enter** button.

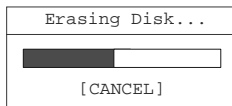

Erase

To begin erasing the disk, use the **Jog** to select **Erase**, then press the **Enter** button. To stop the erasing process, select **[CANCEL]** by pressing the **Enter** button. Data that was erased before **[CANCEL]** was selected will remain deleted permanently.

△CAUTION

Erasing the disk removes recorded data without the possibility of restoring it.

AUDIO RECORD SETTING

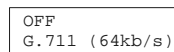

Selecting this menu item will display a sub-menu from which audio recording can be turned on or off. If audio recording is to be enabled, the compression rate will be G.711 (64kb/s).

Use the **Jog** to select **G.711 (64kb/s)** or **OFF**. To confirm the selection and exit the menu, press the **Enter** button. To exit the menu without making changes, press the **Menu** button.

AUTO DELETE MODE

OFF
ON

By selecting this menu item, the Auto Delete function can be turned on and off. Configuring the unit with the Auto Delete mode **ON** prevents the unit from displaying or archiving any data that is more than 30 days old. This feature may be required by law under the Data Protection Act.

Use the Jog to select **ON** of **OFF**. To confirm the selection and exit the menu, press the **Enter** button. To exit the menu without making changes, press the **Menu** button.

COMMUNICATIONS (INCLUDING ETHERNET SETTINGS)

Baud Rate
Ethernet

When the **Communications** menu item is selected, a sub-menu is displayed. Use this sub-menu to specify:

- The data transfer rate for the RS-232 serial port.
- The Ethernet network connection settings for the DTL-960e.

1200 Baud
2400 Baud
4800 Baud
9600 Baud
19200 Baud
38400 Baud
57600 Baud

Baud Rate

Use the **Jog** to select the required Baud Rate.

To confirm the selection and exit the menu, press the **Enter** button. To exit the menu without making changes, press the **Menu** button.

Ethernet Settings	
Ethernet	: DISABLE
IP Address	: 10. 90.253. 10
Subnet Mask	: 255.255. 0. 0
Gateway	: 10. 90. 0. 1
[CANCEL] [OK]	

Ethernet

An Ethernet session is an active network connection between a PC and the unit, with the user viewing live camera images or accessing data stored on the hard disk.

When the Ethernet menu item is first selected, a message appears to warn the user that the machine may restart if any values change. To continue, Select **OK** to continue.

The **Ethernet Settings** menu is displayed, and this menu is used to adjust the Ethernet settings for the network. Use the **Shuttle** to navigate to the desired setting, then use the **Jog** to adjust the value. Consult with your local MIS personnel before making Ethernet setting changes.

To confirm the selection and exit the menu, press the **Enter** button. To exit the menu without making changes, press the **Menu** button.

How the unit handles an Ethernet session

During the Ethernet session, the unit can only be accessed remotely, using the WaveReader software. Playback stops when an Ethernet session is started. Playback will not be re-activated automatically when the Ethernet session ends.

MULTIPLEXER FORMAT

None
ZMX
Robot
Dm
Philips
Sanyo
Pelco

The DTL-960e is compatible with several different brands of multiplexers. Use this menu to specify the Playback format of the multiplexer. If the unit is not connected to a multiplexer, select **None**.

If the unit is connected to a multiplexer, use the **Jog** to select the multiplexer format. To save the changes and exit the menu, press the **Enter** button. To exit the menu without making changes, press the **Menu** button.

ADJUST PICTURE

Brightness
Contrast
Saturation

By selecting the options from the **Adjust Picture** menu, it is possible to specify the **Brightness**, **Contrast** and **Saturation** of the video input. Any adjustments made to the video input will alter the recorded image.

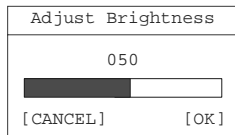
**Brightness**

Use this menu item to increase or decrease the brightness of the image.

1. Use the **Shuttle** to navigate to the numbers.
2. Use the **Jog** to increase or decrease to brightness.
3. To save the changes and exit the menu, use the **Jog** to select **[OK]**, then press the **Enter** button. To exit the menu without making changes, use the **Jog** to select **[CANCEL]**, then press the **Enter** button.

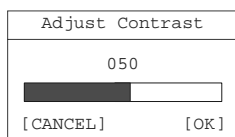
**Contrast**

Use this menu item to increase or decrease the contrast of the image.

1. Use the **Shuttle** to navigate to the numbers.
2. Use the **Jog** to increase or decrease to contrast.
3. To save the changes and exit the menu, use the **Jog** to select **[OK]**, then press the **Enter** button. To exit the menu without making changes, use the **Jog** to select **[CANCEL]**, then press the **Enter** button.

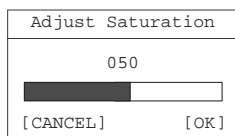
**Saturation**

Use this menu item to increase or decrease the saturation of the image.

1. Use the **Shuttle** to navigate to the numbers.
2. Use the **Jog** to increase or decrease to saturation .
3. To save the changes and exit the menu, use the **Jog** to select **[OK]**, then press the **Enter** button. To exit the menu without making changes, use the **Jog** to select **[CANCEL]**, then press the **Enter** button.

FRONT PANEL LOCK

Unlock Keyboard
Lock Keyboard

When this menu item is selected, a sub-menu is displayed. Use this sub-menu to lock or unlock the buttons on the front panel of the DTL-960e.

Use the **Jog** to select **Unlock Keyboard** or **Lock Keyboard**. To confirm the selection and exit the menu, press the **Enter** button. To exit the menu without making changes, press the **Menu** button.

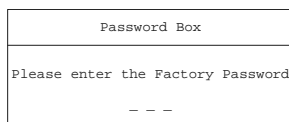
FACTORY SETTINGS

Use this menu to enter the Factory Password, and restore the unit to the factory defaults.

Use the **Jog** to select a number, then use the **Enter** button to complete the selection, and move to the next number. Pressing the **Enter** button on the last number will complete the password selection and return the unit to the factory default configuration.

For more details on the Factory Password, see page 7.

CHANGE PASSWORD

Password Box
Enter a new Password - - -

This menu item is used to change the Main Menu Password.

Use the **Jog** to select a number, then use the **Enter** button to complete the selection, and move to the next number. Pressing the **Enter** button on the last number will open a confirmation box.

Confirmation Box
Please re-enter the Password - - -

Re-enter the new password. Pressing the **Enter** button on the last number will complete the password selection.

Message
The new Password has been Accepted! [OK]

If the password in the confirmation box matches the password from the original password box, this message will appear. Press the **Enter** button to select **[OK]** and exit the menu.

Message
The Password was not changed [OK]

If the password in the confirmation box does not match the password from the original password box, this message will appear. Press the **Enter** button to select **[OK]** and exit the menu.

RS-232 REMOTE PROTOCOL

The RS-232 protocol command structure uses "Start of Text" and "End of Text" characters to identify the beginning and end of command sequences.

The table below shows the command sequences that are supported by the DTL-960e. All byte values are shown in hexadecimal.

Command	1	2	3	4	5
Play Forward	02	46	50	4C	03
Record	02	52	45	43	03
Stop	02	53	54	4F	03
Pause	02	50	41	55	03
Fast Forward	02	46	57	44	03
Rewind	02	52	45	57	03
Frame Forward	02	46	41	44	03
Frame Reverse	02	52	50	44	03
Play Reverse	02	52	50	4C	03
Set Clock	See instructions for setting clock in following section.				

Setting the Clock

The following table shows the command sequence for setting the clock:

Command	1	2	3	4	5	6	7	8	9	10
Value	02	43	4C	4B	20	y1	y2	2D	m1	m2

Command	11	12	13	14	15	16	17	18	19	20
Value	2D	d1	d2	2C	h1	h2	3A	f1	f2	03

Bold text in the Value row of this table indicate the correct positions for each byte of data in the command string.

Place the hexadecimal value of the desired ASCII character into the command string. Enter a two digit value for the Year, Month, Day, Hour, and Minute into the command string. Each digit is a separate byte. Use the last two digits of the year for the year value (For example, 2001 is entered as 01). Time is always designated in Military Time.

Example

In this example, 14:39 on December 25, 2000 is used to demonstrate the Set Clock Command String.

	Notation Used in Value Column	ASCII Character of Desired Value	Hex Value entered into command string
Year Character #1	y1	0	30
Year Character #2	y2	0	30
Month Character #1	m1	1	31
Month Character #2	m2	2	32
Day Character #1	d1	2	32
Day Character #2	d2	5	35
Hour Character #1	h1	1	31
Hour Character #2	h2	4	34
Minute Character #1	f1	3	33
Minute Character #2	f2	9	39

The final Set Clock Command String for 14:39 on December 25, 2000 would appear as follows:

Command	1	2	3	4	5	6	7	8	9	10
Value	02	43	4C	4B	20	30	30	2D	31	32

Command	11	12	13	14	15	16	17	18	19	20
Value	2D	32	35	2C	31	34	3A	33	39	03

FACTORY DEFAULTS

Function	Setting
Time Format	24 Hour
Date Format	MM/DD/YY
Hardwire Alarm	Enabled
Teletext Alarm	Enabled
Alarm Buzzer	Disabled
Record Input	Composite
Normal Record Speed	50 pictures per seconds (Pal)
Alarm Record Speed	50 pictures per seconds (Pal)
Record Quality	High
Display Current Time and Date	Off
Display Record Capacity	Off
Display Last Alarm	Off
Display Archive Status	Off
Display Playback Time and Date	Off
Background Archive Mode	Off
Archive Overwrite Mode	No Overwrite
Disk Overwrite Mode	Overwrite Once
Auto Delete Mode	Off
Baud Rate	9600
Multiplexer	None
Brightness	50%
Contrast	50%
Saturation	50%
Front Panel Locked	Off
Main Menu Password	347
Factory Password	811

TECHNICAL SPECIFICATIONS

General

Power Supply	120-240 Volt AC, Auto-Ranging adapter included
Input Voltage	12 Volt DC
Power Consumption	20 Watts Maximum
Operating Temperature Range	Operating: 0 to 40°C. Storage: -20 to +60°C.
Relative Humidity Range (Non-Condensing)	Operating: 10% to 80%. Storage: 10% to 95%
Dimensions	444 x 356 x 44 mm (17.5 x 14 x 1.75 inches)
Weight	4.5 kg (10 lbs)

Connections

Ethernet Port	10 / 100 Mb RJ-45
Power Connector	2.1mm Barrel Conductor, Center Positive
Accessory I/O Port	DB-Male
SCSI Port	50 Way High Density, SCSI-2 Connector
RS-232 Serial Port	DB-9 Male DTE Connection
SVHS In	4-pin mini-DIN connector (See caution below)
SVHS Out	4-pin mini-DIN connector
Composite Video In	BNC connector (See caution below)
Composite Video Out	BNC connector
Audio In	RCA connector
Audio Out	RCA connector

△ CAUTION

Do not connect both video inputs at the same time.

Video

Video Signal Input	0.7 to 1.4 Volts peak-to-peak, with AGC
Video Signal Output	1 Volt peak-to-peak into 75-ohm
Input Termination	75-ohm
Colors	Y:U:V 4:2:2, 16.8 Million Colors
Gray Scale	256 Levels
Horizontal Resolution	720 Pixels
Vertical Resolution	484 Lines
Compression Standard	Wavelets

On-screen Video Indicators

Archive Status	Pause	Rewind
End of Data	Play	Start of Data
Fast Forward	Record Capacity	Time and Date
Last Alarm	Reverse Play	Video Loss

Baxall Limited reserve the right to make changes to the product and specification of the product without prior notice to the customer.

ARCHIVING DEVICES

This appendix covers the use of archiving devices

CD-ROM disks can be created by attaching a SCSI CD Recording device to the SCSI port of the Digital Recorder. The unit may be a CD Recordable (CD-R), or a CD Rewritable (CD-RW) device.

Requirements are:

- **Minimum Write Speed = 4X**
- **Minimum Read Speed = 16X**

The CD recorder must have a cable that connects to a standard 50-pin High Density SCSI-2 port. The address must be set to Zero (0), and the cable must be properly terminated at 110 Ohms. Failure may result in error messages being displayed on the Digital Recorder when attempting to create CD's.

Do not attempt to archive to the CD unit without a CD properly inserted into the unit. Doing so will generate a **MEDIUM NOT PRESENT** error message.

Creating a CD-ROM with Video Files

In the **Operator** menu, highlight **Archive Setup** and press the **Enter** button. In the resulting sub-menu, highlight **Selective Archive**, and press the **Enter** button. The **Search Filters** menu is displayed. In this menu, the user can search the hard disk for recorded events, such as an alarm condition. These events can then be archived for later viewing. For more details on archiving recorded events to CD, see page 25.

It should be noted that the maximum amount of video data that can be archived on a CD is about 500MB, due to the overhead and housekeeping requirements of the system. If the data to be archived is larger than this, it will not be possible to archive. This is why it is important to filter searches until the data is of a size that can be archived.

Limitations on CD Operations

- Restoring (copying a file from a CD to the Digital Recorder hard disk drive) is not supported.
- Erasing a file recorded on a CD is not supported.
- Playback of files recorded on a CD, through the Digital Recorder, is not supported.

USING TAPE DRIVES

The Digital Recorder supports the use of both DAT (Digital Archive Tape) and AIT (Advanced Intelligent Tape) devices. DAT tapes and drives are available in DDS1 (2GB), DDS2 (4GB), DDS3 (12GB) and DDS4 (25GB) capacities. The Digital Recorder supports only DDS3 and DDS4 tape drives. AIT tapes and drives are available in AIT1 (25GB) and AIT2 (50GB) capacities. The Digital Recorder supports both.

Both the DAT and AIT devices are available in multiple tape configurations. These are called Autoloader or Carousel devices. The DAT Autoloader magazine holds eight tapes or seven tapes and a cleaning cartridge. The seven tapes with a cleaning cartridge configuration is recommended for DAT Autoloaders. The AIT Carousel unit holds four tapes.

While less complex, the operation of single tape DAT and AIT devices is very similar to the multiple tape devices. Most of the same buttons and indicators are present. As a result, this appendix will cover operation of the more complex Autoloader units in greater detail than the single tape devices.

USING SINGLE TAPE UNITS

Single tape DAT devices may be used for selective archiving but are not recommended for background archiving operations. This is because the units have a diagnostic routine that stops the recording operation after each 24 hours of continuous use. When this occurs, the unit requires that a cleaning tape be inserted before recording operations can begin again. This presents the possibility that recording may halt in the middle of an extended archiving situation. AIT single tape devices and Autoloader units do not have this limitation.

The single tape units have an EJECT button, a POWER button, and LEDs for unit status. These may include STATUS (cleaning required and fault condition), TAPE (tape present or tape fault), BUSY (tape present and busy) and a POWER indicator. The exact names and quantity of indicators varies with the different manufacturers products and drive type. The EJECT button will unload a tape from the drive and eject it from the unit. The tape cartridge has a write-protection tab, which prevents data being written to it.

To use the unit, press the POWER switch on the front panel. The POWER indicator should light, and the LEDs may blink or be on steady as the unit performs a self test. When the self-test is completed a tape cartridge may be inserted. The indicators may blink if the tape cartridge is write protected, and there is normally some indication of a BUSY status before the tape is fully loaded.

Software drivers in the Digital Recorder control the reading and writing operations of the tape. When the unit is reading or writing, a BUSY status should be visible. For more information on how to search for and select data for archiving, see page 25.

To remove a tape from the unit, press the EJECT button. The cartridge will eject automatically. Do not push the EJECT button while the unit is indicating a BUSY status. To do so will result in lost data and may also destroy data on the tape.

USING AUTOLOADER DEVICES

The Autoloader devices may have a SELECT button, an EJECT button, an LCD display, and status LEDs for tape present and busy status. The SELECT button is automatically disabled once the tape load sequence begins. Tape selection will be controlled by software. The EJECT button will unload a tape from the drive and eject the full magazine from the Autoloader. The magazine has a write-protection tab, which prevents data being written to all tapes in the magazine.

LOADING THE MAGAZINE

For correct operation, the magazine should contain from one to eight data tapes, depending on the unit being used. Some of the possible configurations are as follows:

One Data Tape

SONY TSL-S9000L: (DDS3) - Requires a single data tape in Slot 8. Proceed as follows:

1. The tape should be labelled as tape 1 before being inserted into the magazine. In this mode, the Autoloader functions as a single tape drive device.
2. If Slot 8 of the magazine contains a cleaning tape, the cleaning tape will be loaded into the drive, the tape heads will be cleaned, and the tape will be returned to the magazine.

Four Data Tapes

SONY TSL-SA300C: (AIT1) - Requires four data tapes in the magazine. Proceed as follows:

1. The tapes should be labelled as tape 1 to 4 before they are inserted into the magazine.
2. Insert tapes 2 and 1 (in that order) into the bottom shelf.
3. Insert tapes 3 and 4 (in that order) into the top shelf.

Note: All four tapes must be loaded in order for this unit to work.

Seven Data Tapes

SONY TSL-S9000L: (DDS3) - Requires seven data tapes and one cleaning tape in the magazine. Proceed as follows:

1. The tapes should be labelled as tape 1 to 7 before they are inserted into the magazine.
2. The magazine should contain seven tapes in slots 1 to 7, and a cleaning tape in slot 8 to operate correctly.

Eight Data Tapes

SONY TSL-S9000L: (DDS3) - Requires eight data tapes and no cleaning tape. Proceed as follows:

1. In this case, it is the operator's responsibility to clean the tape drive periodically. Because data can be lost if the heads become dirty during archiving, this mode of operation is not recommended for continuous background archiving.
2. The tapes should be labelled as tape 1 to tape 8 before they are inserted into the magazine.
3. Insert tapes 3, 2, and 1 (in that order) into the bottom shelf.
4. Insert tapes 4, 5, 6, and 7 (in that order) into the top shelf.
5. Insert tape 8 in the last slot. Tape 8 is a data tape.

DRIVE OPERATION

When a magazine is inserted into the Autoloader, the changer cycles through all the tapes to ensure that the magazine is full. If any tape slots are empty, the magazine is ejected from the drive.

Once all tapes have been detected, Tape 1 is loaded into the drive. The tape headers are read and compared to the volume files on the disk to find a match.

- If a matching volume is found, the volume files for the other tapes in the magazine are sought on the disk. No other tapes are loaded.
- If no matching volume file is found on the disk, all the tapes in the magazine are loaded in sequence. Each tape's headers are saved to the disk.

Only when the headers from all the tapes in the magazine have been stored on the disk, can the device be used for archiving.

VOLUME INFORMATION

The Wavelet data headers that are stored at the beginning of a tape are stored in special files on the hard disk. This volume information is stored on the hard disk to enable the contents on a tape to be recovered quickly in case the tape drive was powered down while recording.

The volume information on the disk is also used to reference other tapes in the magazine. This speeds up the magazine loading process, as only one tape has to be read to know the contents of the other tapes in the magazine. For this reason, it is not advisable to change the order of the tapes in a magazine.

The software currently supports 32 volume partitions on the hard disk. When all available partitions on the hard disk have been allocated, the oldest partition will be cleared and reused. Each time a tape is loaded, the time stamp in the corresponding partition is updated. When factory settings are selected, all volume partitions are erased.

RESTORING TAPE HEADERS

- If the SCSI link between the Digital Recorder and the tape drive fails while data is being written to the tape, as much data as possible is restored when the link is re-established. Most of the header information is recovered from the disk, with the remaining data recovered from the tape. This recovery operation typically takes several minutes, depending on the relative position of the data from the start of the tape.
- If the power to the drive is interrupted while the drive was writing data to tape, the data recovery process may take considerably longer because the position of the last valid data must be determined.

WRITE-PROTECTION

The magazine can be write protected by moving the write protect tab to the Save position. In addition, individual tapes can be write protected by opening the write protect tab on the tape.

- If a write protected tape is chosen for selective archiving, no data will be written to the tape.
- If a write protected tape is loaded during background archiving, the tape is returned to the carousel, and the next tape in sequence will be loaded.

BLANK TAPES

If any blank tape is detected during the loading process, the tape will automatically be partitioned into two partitions, and a blank set of headers will be written to the tape, so they are ready to receive recordings.

TAPE CAPACITY

The tape capacity is read from the drive when a new tape is being loaded. The capacity reported by the drive is only an estimate, and varies with the make of the drive and tape. This estimated value is used in computing the percentage of space left while background archiving (or when selecting events are to be archived).

ERASE MEDIUM

If more than one volume is detected, the user can use the **Erase Archive Medium** menu item to select one or more volumes to erase. All selections will be off by default. More than one volume can be selected per erase operation.

- If the selected volume is in the tape drive, the header partition on the loaded tape is erased.
- If the selected volume is not in the drive, the selected tape is loaded and the headers are read. The tape is erased only if the headers read from the tape match those on the disk for that position in the magazine.
- If the headers on the tape are different from those on the disk, the tape positions in the magazine must have been changed. In which case, the tape is not erased. The tape in position one must be removed, a new reading of the magazine begins, and tapes will be erased.

The progress bar tracks the erase operation. It reaches 100% when all selected tapes have been erased. The bar is not updated smoothly, but rather in stages during the erase operation. The progress bar does not change while a tape is being selected (up to 3 minutes). The tapes are erased in sequence starting with the lowest selected ID, regardless of which tape was originally in the drive.

Note: When background archiving is active, certain tape functions are not available, such as **Erase Archive Medium**. In order to erase a tape, turn background archiving mode off. See page 26 for details on how to do this.

STUCK TAPES

Autoloaders do not always boot reliably when powered on with a tape in the drive. During the initialisation sequence, one of the tapes from the magazine may become dislodged from the magazine and will have to be removed manually from the Autoloader and replaced in the magazine. This seems to be either a drive or magazine feature, which the software cannot remedy. As a result:

- The use of an uninterruptible power supply (UPS) is recommended when using the Autoloader.
- Be sure that the magazine is ejected from the Autoloader before removing power.

Note: If the Autoloader is powered on with a tape in the drive, the headers from that tape are read (and restored if necessary), and the loaded tape is used as the reference tape. If this occurs, the SELECT button on the Autoloader is enabled until a different tape is loaded. **Do not press the SELECT button at this time.** Doing so will cause a new tape to be loaded.

CLEANING CYCLE

The cleaning tape is loaded during background archiving without any user intervention. It is loaded when:

- It is the next tape in sequence.
- At least two tapes have been written to the End of Media.

The heads are cleaned, and the tape is returned to the magazine. The next tape in sequence is then loaded. The cleaning tape is not used during selective archiving.

If the magazine volume information is not found to be on the hard disk during the initial loading sequence, the cleaning tape is loaded. If (a) all the tapes in the magazine are full, (b) at least two tapes have received data since the last cleaning cycle, and (c) the background archiving mode is either **No Overwrite** or **Write Once**, the heads are cleaned before the magazine is ejected.

DATA TRANSFER OPERATIONS

There are four data transfer operations that can be carried out using the Digital Recorder and a tape drive:

- Selective Archive
- Restore from Archive
- Play from Tape
- Background Archive

Selective Archive Mode

If more than one volume is found, a list of available volumes is displayed. The loaded volume is selected by default. Selecting a volume deselects the previously selected volume.

When a volume has been selected, and the menus have been exited, pressing the **SEARCH** button displays (1) the selected events on the disk, and (2) the free capacity of the selected volume. Pressing the **RECORD** button starts the copying of events from the disk to the tape.

If the selected tape is not the tape in the drive, the other tapes in the magazine are loaded in succession until the matching tape is found. If no matching tape is found, no information is archived to the tape. It is possible to select only events that will fit on the tape. The capacity of the tape is determined when the tape is loaded.

The **Remaining Capacity** parameter is only an approximate value. In some cases the EOM may be encountered before the complete event has been written. In this case, the headers on the tape are updated, but the full tape will not be ejected from the drive. A message appears indicating that not all information was archived. In Selective Archive Mode, a tape can be erased.

Restore from Archive Mode

If more than one volume is found, a list of available volumes is displayed. The loaded volume is selected by default. Selecting a volume deselects the previously selected volume.

When a volume has been selected, and the menus have been exited, pressing the **SEARCH** button displays (1) the selected events on the disk, and (2) the free capacity of the selected volume. Pressing the **RECORD** button starts the copying of events from the tape to the disk.

If the selected tape is not the tape in the drive, the other tapes in the magazine are loaded in succession until the matching tape is found. If no matching tape is found, no information is restored from the tape.

Play from Tape Mode

If more than one volume is found, a list of available volumes is displayed. The loaded volume is selected by default. Selecting a volume deselects the previously selected volume.

When a volume has been selected, and the menus have been exited, pressing the **SEARCH** button displays (1) the selected events on the disk, and (2) the free capacity of the selected volume.

Pressing the **ENTER** button plays back an event from the **Restore Search Results** screen. If the selected tape is not the tape in the drive, the other tapes in the magazine are loaded in succession until the matching tape is found. If no matching tape is found, nothing is played back. Do not cancel a search, or start another search, while the autoloader is unloading or loading tapes.

Background Archive Mode

If the Autoloader is being used with a single tape in Slot 8, the Autoloader functions as a single-tape drive. The tape is unloaded when full regardless of the background archiving setting.

If more than one tape is used, all tapes in the magazine are searched to find the most recent event. If all the tapes are blank, Tape 1 is selected.

During background archiving, the **Archive Percentage** and **Time Left** parameters indicate the estimated time left for the magazine, not just for the current tape. Information is written until the EOM is encountered. This may be slightly greater or less than the reported tape capacity. The remaining time left is recalculated when the next tape is loaded to overcome this difference. If a loaded tape is write protected or not usable, the archive time is adjusted accordingly when the next tape is loaded.

Note: When background archiving is active, certain tape functions are not available, such as **Erase Archive Medium**. In order to erase a tape, switch background archiving off. See page 26 for details on how to do this.

There are three different overwrite modes that can be used with an Autoloader, and these modes should be considered when background archiving is used. These modes are:

- **No Overwrite**

The Autoloader finds the tape with the most recent recorded event, and the next tape in sequence is then selected as the starting point. When that tape becomes full, the magazine is sequentially searched for a tape with free space. If one is found, it is loaded and archiving continues. Otherwise, the magazine is ejected, and another magazine must be inserted. The magazine changeover operation may take a number of minutes to perform, in which case some data may be lost.

- **Overwrite Once**

The tape with the most recent recorded event is found, and the next tape in sequence is selected as the starting point. This tape is loaded and erased, so that archived information starts at the beginning of the tape. The **Archive Percentage** and **Time Left** parameters then indicate the remaining capacity of the magazine. When these decrease to zero, all the tapes in the magazine are full, and the magazine is ejected, at which point another magazine must be inserted. The magazine changeover operation may take a number of minutes to perform, in which case some data may be lost.

- **Continuous Overwrite**

This mode operates in the same way as Overwrite Once mode, but when all the tapes in the magazine are full, the cleaning tape is loaded and run. The operation recycles until archiving or recording is turned off. The magazine is not ejected in this mode.

For more details on archive overwrite modes and on archiving in general, see page 25 and 26.

ARCHIVE ERROR MESSAGES

The archiving error messages have been expanded to display different text strings. The alarm relay will only be set if the string is **Archiving Failed**.

Mode	Message	Reason
Selective Archive	Medium not present.	The tape cannot be selected.
“ “	Not all data was archived.	1) Reached EOM on the tape. 2) The Archive Mode is turned OFF.
“ “	Medium is write-protected.	Cannot write to tape as write tab is open.
“ “	Archiving Failed. †	1) The write command failed. 2) The drive is disconnected.
Restore From Archive	Medium not present.	The tape cannot be selected.
“ “ “	Not all data was archived.	The Archive Mode is turned off.
“ “ “	Can't read medium.	1) The read command failed. 2) The drive is disconnected.
Play From Tape	Can't read medium.	1) The read command failed. 2) The drive is disconnected.
Background Archive	Archiving Failed. †	1) The write command failed. 2) The drive is disconnected.
† The alarm relay is set if this message appears.		

THE ARCHIVING ICON

When the unit exits Record mode during archiving, a white tape icon appears in the bottom right hand corner of the monitor. It indicates that archiving is in progress. The icon remains until all information has been written to tape, and the tape headers have been updated.

If the tape or magazine becomes full before all the information has been written to the tape, the magazine is ejected, and the archive icon remains on the monitor. The icon is cleared when a new tape or magazine is loaded.

Turning off the Archive mode in the menus can also clear the icon. This action also flushes the remaining data buffers. This operation may take a while if a tape is being loaded or the magazine is being ejected.

Note: The Digital Recorder should not be turned off if the archive icon is visible and data is still being written to tape.

Baxall Limited, Stockport, England. Visit our Web site: <http://www.baxall.com>

Baxall Limited reserve the right to make changes to the product and specification of the product without prior notice to the customer.